

## TABLE OF CONTENTS

### SECTION 9

#### SUPPLEMENTS

Paragraph/Supplement No.	Page No.
9.1 General .....	9-1
1 Air Conditioning Installation .....	9-3
2 AutoFlite II Autopilot Installation .....	9-7
3 AutoControl IIIB Autopilot Installation .....	9-9
4 Piper Electric Pitch Trim .....	9-13
5 Century 21 Autopilot Installation .....	9-15
6 Piper Control Wheel Clock Installation .....	9-19
7 King KAP 100 Series Flight Control System .....	9-21
8 King KAP 150 Series Flight Control System .....	9-41
9 KNS 80 Navigation System .....	9-67
10 Auxiliary Vacuum System .....	9-71
11 Bendix/King KLN 90 GPS Navigation System .....	9-77

**SECTION 9  
SUPPLEMENTS**

**9.1 GENERAL**

This section provides information in the form of Supplements which are necessary for efficient operation of the airplane when equipped with one or more of the various optional systems and equipment not provided with the standard airplane.

All of the Supplements provided by this section are "FAA Approved" and consecutively numbered as a permanent part of this Handbook. The information contained in each Supplement applies only when the related equipment is installed in the airplane.

**THIS PAGE INTENTIONALLY LEFT BLANK**

**SUPPLEMENT 1**

**AIR CONDITIONING INSTALLATION**

**SECTION 1 - GENERAL**

This supplement supplies information necessary for the efficient operation of the airplane when the optional air conditioning system is installed. The information contained within this supplement is to be used "as described" in conjunction with the complete handbook.

This supplement has been "FAA Approved" as a permanent part of this handbook and must remain in this handbook at all times when the optional air conditioning system is installed.

**SECTION 2 - LIMITATIONS**

- (a) To insure maximum climb performance the air conditioner must be turned OFF manually prior to takeoff to disengage the compressor and retract the condenser door. Also the air conditioner must be turned OFF manually before the landing approach in preparation for a possible go-around.
- (b) Placards  
In full view of the pilot, in the area of the air conditioner controls when the air conditioner is installed:

**"WARNING - AIR CONDITIONER MUST  
BE OFF TO INSURE NORMAL TAKEOFF  
CLIMB PERFORMANCE."**

In full view of the pilot, to the right of the engine gauges (condenser door light):

**"AIR COND DOOR  
OPEN"**

**SECTION 3 - EMERGENCY PROCEDURES**

No changes to the basic Emergency Procedures provided by Section 3 of this Pilot's Operating Handbook are necessary for this supplement.

**SECTION 4 - NORMAL PROCEDURES**

Prior to takeoff, the air conditioner should be checked for proper operation as follows:

- (a) Check aircraft master switch ON.
- (b) Turn the air conditioner control switch to ON and the fan switch to one of the operating positions - the "AIR COND DOOR OPEN" warning light will turn on, thereby indicating proper air conditioner condenser door actuation.
- (c) Turn the air conditioner control switch to OFF - the "AIR COND DOOR OPEN" warning light will go out, thereby indicating the air conditioner condenser door is in the up position.
- (d) If the "AIR COND DOOR OPEN" light does not respond as specified above, an air conditioner system or indicator bulb malfunction is indicated and further investigation should be conducted prior to flight.

The above operational check may be performed during flight if an in flight failure is suspected.

The condenser door light is located to the right of the engine instrument cluster in front of the pilot. The door light illuminates when the door is open and is off when the door is closed.

**SECTION 5 - PERFORMANCE**

Operation of the air conditioner will cause slight decreases in cruise speed and range. Power from the engine is required to run the compressor, and the condenser door, when extended, causes a slight increase in drag. When the air conditioner is turned off there is normally no measurable difference in climb, cruise or range performance of the airplane.

**NOTE**

To insure maximum climb performance the air conditioner must be turned off manually before takeoff to disengage the compressor and retract the condenser door. Also the air conditioner must be turned off manually before the landing approach in preparation for a possible go-around.

Although the cruise speed and range are only slightly affected by the air conditioner operation, these changes should be considered in preflight planning. To be conservative, the following figures assume that the compressor is operating continuously while the airplane is airborne. This will be the case only in extremely hot weather.

- (a) The decrease in true airspeed is approximately 4 KTS at all power settings.
- (b) The decrease in range may be as much as 32 nautical miles for the 48 gallon capacity.

The climb performance is not compromised measurably with the air conditioner operating since the compressor is declutched and the condenser door is retracted, both automatically, when a full throttle position is selected. When the full throttle position is not used or in the event of a malfunction which would cause the compressor to operate and the condenser door to be extended, a decrease in rate of climb of as much as 100 fpm can be expected. Should a malfunction occur which prevents condenser door retraction when the compressor is turned off, a decrease in rate of climb of as much as 50 fpm can be expected.

**SECTION 6 - WEIGHT AND BALANCE**

Factory installed optional equipment is included in the licensed weight and balance data in Section 6 of the Pilot's Operating Handbook.

**SECTION 7 - DESCRIPTION AND OPERATION**

No change.

**THIS PAGE INTENTIONALLY LEFT BLANK**

**SUPPLEMENT 2**

**AUTOFLITE II AUTOPILOT INSTALLATION**

**SECTION 1 - GENERAL**

This supplement supplies information necessary for the operation of the airplane when the optional AutoFlite II Autopilot is installed. The information contained within this supplement is to be used "as described" in conjunction with the complete handbook.

This supplement has been "FAA Approved" as a permanent part of this handbook and must remain in this handbook at all times when the optional AutoFlite II Autopilot is installed.

**SECTION 2 - LIMITATIONS**

- (a) Autopilot use prohibited above 149 KIAS.
- (b) Autopilot OFF during takeoff and landing.

**SECTION 3 - EMERGENCY PROCEDURES**

- (a) In case of malfunction DEPRESS and hold Disconnect switch on pilot's control wheel.
- (b) Rocker switch on instrument panel OFF.
- (c) Unit may be overpowered manually.
- (d) In climb, cruise or descent configuration a malfunction with a 3 second delay in recovery initiation may result in 45° bank and 180' altitude loss. Maximum altitude loss measured at 149 KIAS in a descent.
- (e) In approach configuration a malfunction with a 1 second delay in recovery initiation results in 18° bank and 10' altitude loss.



**SECTION 4 - NORMAL PROCEDURES**

- (a) Engagement
  - (1) Rocker Switch on instrument panel - ON.
  - (2) Disconnect Switch on left hand side of pilot's control wheel - RELEASED.
  
- (b) Disengagement
  - (1) Depress Disconnect Switch on pilot's control wheel (or)
  - (2) Rocker Switch on instrument panel - OFF.
  
- (c) Heading Changes
  - (1) Depress Disconnect Switch, make Heading Change, release Disconnect Switch.
  - (2) Move Trim Knob on instrument for Drift Correction from a constant heading.
  - (3) Move Turn Command Knob on instrument for right or left banked turns.
  
- (d) OMNI Tracker
  - (1) Center Turn Command Knob and push IN to engage Tracker.
  - (2) Trim Knob - push IN for high sensitivity.

**SECTION 5 - PERFORMANCE**

No changes to the basic performance provided by Section 5 of this Pilot's Operating Handbook are necessary for this supplement.

### SUPPLEMENT 3

#### AUTOCONTROL IIB AUTOPILOT INSTALLATION

##### SECTION 1 - GENERAL

This supplement supplies information necessary for the operation of the airplane when the optional Piper AutoControl IIB Autopilot is installed. The information contained within this supplement is to be used as described in conjunction with the complete handbook.

This supplement has been FAA Approved as a permanent part of this handbook and must remain in this handbook at all times when the optional Piper AutoControl IIB Autopilot is installed.

##### SECTION 2 - LIMITATIONS

- (a) Autopilot use prohibited above 149 KIAS.
- (b) Autopilot OFF during takeoff and landing.

##### SECTION 3 - EMERGENCY OPERATION

- (a) In an emergency the AutoControl IIB can be disconnect by pushing the roll ON-OFF Rocker Switch OFF.
- (b) The autopilot can be overpowered at either control wheel.
- (c) An autopilot runaway, with a 3 second delay in the initiation of recovery while operating in a climb, cruise or descending flight, could result in a 45° bank and 180' altitude loss. Maximum altitude loss measured at 149 KTS in a descent.
- (d) An autopilot runaway, with a 1 second delay in the initiation of recovery, during an approach operation, coupled or uncoupled, could result in a 18° bank and 10' altitude loss.

**SECTION 4 - NORMAL PROCEDURES**

**PREFLIGHT**

**(a) AUTOPILOT**

- (1) Place Radio Coupler in "HDG" Mode (if installed) and place the AP ON-OFF switch to the ON position to engage roll section. Rotate roll command knob left and right and observe that control wheel describes a corresponding left and right turn, then center knob.
- (2) Set correct compass heading on D.G. and turn HDG bug to aircraft heading. Engage "HDG" mode rocker switch and rotate HDG bug right and left. Aircraft control wheel should turn same direction as bug. Grasp control wheel and manually override servo, both directions.

**(b) RADIO COUPLER (OPTIONAL)**

- (1) Tune and identify VOR or VOT station. Position Radio Coupler to OMNI Mode. Engage Autopilot ON and HDG switches. Set HDG bug to aircraft heading and rotate O.B.S. to cause OMNI indicator Needle to swing left and right slowly. Observe that control wheel rotates in direction of needle movement.
- (2) Disengage AP ON-OFF switch. Reset Radio Coupler control to HDG.

**IN-FLIGHT**

- (a) Trim airplane (ball centered).
- (b) Check air pressure vacuum to ascertain that the directional gyro and attitude gyro are receiving sufficient air.
- (c) Roll Section.
  - (1) To engage, center ROLL knob, push AP ON-OFF switch to ON position. To turn, rotate console ROLL knob in desired direction. (Maximum angle of bank should not exceed 30.)
  - (2) For heading mode, set directional gyro with magnetic compass. Push directional gyro HDG knob in, rotate bug to aircraft heading. Push console heading rocker (HDG) switch to ON position. To select a new aircraft heading, push D.G. heading knob IN and rotate, in desired direction of turn, to the desired heading.

- (d) Radio Coupling — VOR/ILS with Standard directional gyro.  
(Optional)
- (1) For VOR Intercepts and Tracking:  
Select the desired VOR course and set the HDG bug to the same heading. Select OMNI mode on the coupler and HDG Mode on the autopilot console.
- (2) For ILS Front Course Intercepts and Tracking:  
Tune the localizer frequency and place the HDG bug on the inbound, front course heading. Select LOC-NORM mode on the coupler and HDG mode on the autopilot console.
- (3) For LOC Back Course Intercepts and Tracking:  
Tune the localizer frequency and place the HDG bug on the inbound course heading to the airport. Select LOC-REV mode with coupler and HDG mode on the autopilot console.

#### **SECTION 5 - PERFORMANCE**

No changes to the basic performance provided by Section 5 of this Pilot's Operating Handbook are necessary for this supplement.

**THIS PAGE INTENTIONALLY LEFT BLANK**

**SUPPLEMENT 4**

**PIPER ELECTRIC PITCH TRIM**

**SECTION 1 - GENERAL**

This supplement supplies information necessary for the operation of the airplane when the optional Piper Electric Pitch Trim is installed. The information contained within this supplement is to be used "as described" in conjunction with the complete handbook.

This supplement has been "FAA Approved" as a permanent part of this handbook and must remain in this handbook at all times when the optional Piper Electric Pitch Trim is installed.

**SECTION 2 - LIMITATIONS**

No changes of the basic limitations provided by Section 2 of this Pilot's Operating Handbook are necessary for this supplement.

**SECTION 3 - EMERGENCY PROCEDURES**

- (a) In case of malfunction, **ACTIVATE** disconnect switch located above the ignition switch, to **OFF** position.
- (b) In case of malfunction, overpower the electric trim at either control wheel.
- (c) Maximum altitude change with a 4 second delay in recovery initiation is 800 feet and occurs in the descent configuration. Maximum altitude change in the approach configuration with a 4 second recovery delay is 100 feet.

**SECTION 4 - NORMAL PROCEDURES**

The electric trim system may be turned ON or OFF by a switch located above the ignition switch. The pitch trim may be changed when the electric trim system is turned on either by moving the manual pitch trim control wheel or by operating the trim control switch on the pilot's control yoke. To prevent excessive speed increase in the event of an electric trim runaway malfunction, the system incorporates an automatic disconnect feature which renders the system inoperative above approximately 143 KIAS. The disconnected condition does not affect the manual trim system.

**SECTION 5 - PERFORMANCE**

No changes to the basic performance provided by Section 5 of this Pilot's Operating Handbook are necessary for this supplement.

**SUPPLEMENT 5**

**CENTURY 21 AUTOPILOT INSTALLATION**

**SECTION 1 - GENERAL**

This supplement supplies information necessary for the operation of the airplane when the optional Century 21 Autopilot is installed in accordance with STC SA3352SW. The information contained within this supplement is to be used in conjunction with the complete handbook.

This supplement has been 'FAA Approved' as a permanent part of this handbook and must remain in this handbook at all times when the optional Century 21 Autopilot is installed.

**SECTION 2 - LIMITATIONS**

- (a) Autopilot operation prohibited above 147 KIAS.
- (b) Autopilot OFF during takeoff and landing.

**SECTION 3 - EMERGENCY PROCEDURES**

**(a) AUTOPILOT**

In the event of an autopilot malfunction, or anytime the autopilot is not performing as commanded, do not attempt to identify the problem. Regain control of the aircraft by overpowering and immediately disconnecting the autopilot by depressing the AP ON-OFF switch on the programmer OFF.

Do not operate until the system failure has been identified and corrected.



**(1) Altitude Loss During Malfunction:**

- a. An autopilot malfunction during climb, cruise or descent with a 3 second delay in recovery initiation could result in as much as a 45° of bank and 180' altitude loss. Maximum altitude loss was recorded at 147' KIAS during descent.
- b. An autopilot malfunction during an approach with a 1 second delay in recovery initiation could result in as much as 18° bank and 10' altitude loss. Maximum altitude loss measured in approach configuration, and operating either coupled or uncoupled.

**(b) COMPASS SYSTEM**

**(1) Emergency Operation With Optional NSD 360A (HSI) Slaved and/or Non-Slaved:**

**NSD 360A**

- a. Appearance of HDG Flag:
  1. Check air supply gauge (vac or pressure) for adequate air supply (4 in. Hg. min.)
  2. Check compass circuit breaker.
  3. Observe display for proper operation.
- b. To disable heading card - pull circuit breaker and use magnetic compass for directional data.

**NOTE**

If heading card is not operational, autopilot should not be used.

- c. With card disabled VOR/Localizer and Glide Slope displays are still functional; use card set to rotate card to aircraft heading for correct picture.
- d. Slaving Failure - (i.e. failure to self correct for gyro drift):
  1. Check gyro slaving switch is set to No. 1 position (if equipped with Slave No. 1 - No. 2 switch) or "Slaved" position when equipped with Slaved and Free Gyro Mode Switch.
  2. Check for HDG Flag.
  3. Check compass circuit breaker.
  4. Reset heading card while observing slaving meter.

**NOTE**

Dead slaving meter needle or a needle displaced fully one direction indicates a slaving system failure.

5. Select slaving amplifier No. 2 if equipped.
6. Reset heading card while checking slaving meter. If proper slaving indication is not obtained, switch to free gyro mode and periodically set card as an unslaved gyro.

**NOTE**

In the localizer mode, the "TO-FROM" arrows may remain out of view, depending upon the design of the NAV converter used in the installation.

**SECTION 4 - NORMAL PROCEDURES**

Refer to Edo-Aire Mitchell Century 21 Autopilot Operator's Manual, P/N 68S805, dated 1-79 for Autopilot Description and Normal Operating Procedures.

**(a) PREFLIGHT PROCEDURES**

**NOTE**

During system functional check the system must be provided adequate D.C. voltage (12.0 VDC min.) and instrument air (4.2 in. Hg. min.). It is recommended that the engine be operated to provide the necessary power and that the aircraft be positioned in a level attitude, during the functional check.

- (b) **AUTOPILOT WITH STANDARD D.G.**
  - (1) Engage autopilot.
  - (2) Control wheel movement should correspond to HDG command input.
  - (3) Grasp control wheel and override roll servo actuator to assure override capability.
  - (4) With HDG bug centered select NAV or APPR mode and note control wheel movement toward VOR needle offset.
  - (5) Select REV mode and note control wheel movement opposite VOR needle offset.
  - (6) Disengage autopilot.
  - (7) Check aileron controls through full travel to assure complete autopilot disengagement.
- (c) **AUTOPILOT WITH COMPASS SYSTEM (NSD 360A)**

(For other compass systems, refer to appropriate manufacturer's instructions)

  - (1) Check slaving switch in slave or slave 1 or 2 position, as appropriate. (Slaving systems with R.M.I. output provide only slave and free gyro positions.)
  - (2) Rotate card to center slaving meter - check HDG displayed with magnetic compass HDG.
  - (3) Perform standard VOR receiver check.
  - (4) Perform Steps (1) - (7) in Section 4 item (b) except in Steps (4) and (5) substitute course arrow for HDG bug when checking control wheel movement in relation to L/R needle. HDG bug is inoperative with NAV, APPR. or REV mode selected.
- (d) **IN-FLIGHT PROCEDURE**
  - (1) Trim aircraft for existing flight condition (all axes).
  - (2) Rotate heading bug to desired heading. Engage autopilot.
  - (3) During maneuvering flight - control aircraft through use of the HDG bug. (HDG mode)
  - (4) For navigation operations select modes as required by the operation being conducted and in accordance with the mode description provided in the Century 21 Operator's Manual.

**SECTION 5 - PERFORMANCE**

No changes to the basic performance provided by Section 5 of this Pilot's Operating Handbook are necessary for this supplement.

**SUPPLEMENT 6**

**PIPER CONTROL WHEEL CLOCK INSTALLATION**

**SECTION 1 - GENERAL**

This supplement supplies information necessary for the operation of the airplane when the optional Piper Control Wheel Clock is installed. The information contained within this supplement is to be used in conjunction with the complete handbook.

This supplement has been "FAA Approved" as a permanent part of this handbook and must remain in this handbook at all times when the optional Piper Control Wheel Clock is installed.

**SECTION 2 - LIMITATIONS**

No changes to the basic limitations provided by Section 2 of this Pilot's Operating Handbook are necessary for this supplement.

**SECTION 3 - EMERGENCY PROCEDURES**

No changes to the basic Emergency Procedures provided by Section 3 of this Pilot's Operating Handbook are necessary for this supplement.

**SECTION 4 - NORMAL PROCEDURES**

(a) **SETTING**

While in the CLOCK mode, the time and the date can be set by the operation of the RST button.

**(b) DATE SETTING**

Pressing the RST button once will cause the date to appear with the month flashing. Pressing the ST-SP button will advance the month at one per second, or at one per push, until the right month appears.

Pressing the RST button once again will cause the date to flash, and it can be set in a similiar manner.

**(c) TIME SETTING**

The RST button must now be pressed two times to cause the hours digits to flash. The correct hour can be set in as described above.

Pressing the RST button once again will now cause the minutes digits to flash. The minutes should be set to the next minute to come up at the zero seconds time mark. The RST button is pressed once more to hold the time displayed. At the time mark, the ST-SP button is pressed momentarily to begin the time counting at the exact second.

If the minutes are not advanced when they are flashing in the set mode, pressing the RST button will return the clock to the normal timekeeping mode without altering the minutes timing. This feature is useful when changing time zones, when only the hours are to be changed.

**(d) AUTOMATIC DATE ADVANCE**

The calendar function will automatically advance the date correctly according to the four year perpetual calendar. One day must be added manually on Feb. 29 on leap year. The date advances correctly at midnight each day.

**(e) DISPLAY TEST**

Pressing both the RST and ST-SP buttons at the same time will result in a display test function.

**SECTION 5 - PERFORMANCE**

No changes to the basic performance provided by Section 5 of this Pilot's Operating Handbook are necessary for this supplement.

**PILOT'S OPERATING HANDBOOK  
AND  
FAA APPROVED AIRPLANE FLIGHT MANUAL  
  
SUPPLEMENT NO. 7  
FOR  
KING KAP 100 SERIES FLIGHT CONTROL SYSTEM**

This supplement must be attached to the Pilot's Operating Handbook and FAA Approved Airplane Flight Manual when the King KAP 100 Series Flight Control System is installed in accordance with STC SA1565CE-D. The information contained herein supplements or supersedes the information in the basic Pilot's Operating Handbook and FAA Approved Airplane Flight Manual only in those areas listed herein. For limitations, procedures and performance information not contained in this supplement, consult the basic Pilot's Operating Handbook and FAA Approved Airplane Flight Manual.

FAA APPROVED Ward Evans  
WARD EVANS  
D.O.A. NO. SO-1  
PIPER AIRCRAFT CORPORATION  
VERO BEACH, FLORIDA

DATE OF APPROVAL JULY 21, 1982

## **SECTION 1 - GENERAL**

This supplement supplies information necessary for the operation of the airplane when the optional King KAP 100 Series Flight Control System is installed. The Flight Control System must be operated within the limitations herein specified. The information contained within this supplement is to be used in conjunction with the complete handbook.

This supplement has been FAA Approved as a permanent part of this handbook and must remain in this handbook at all times when the optional King KAP 100 Series Flight Control System is installed.

## **SECTION 2 - LIMITATIONS**

The autopilot must be OFF during takeoff and landing.

## **SECTION 3 - EMERGENCY PROCEDURES**

### **(a) SYSTEM WITH AUTOPILOT ONLY**

- (1) In case of Autopilot malfunction: (accomplish items a. and b. simultaneously)
  - a. Airplane Control Wheel - GRASP FIRMLY and regain aircraft control.
  - b. AP ENG Button - PRESS to disengage autopilot.

### **(b) SYSTEMS WITH AUTOPILOT AND OPTIONAL MANUAL ELECTRIC TRIM**

- (1) In case of Autopilot malfunction: (accomplish items a. and b. simultaneously)
  - a. Airplane Control Wheel - GRASP FIRMLY and regain aircraft control.
  - b. AP DISC/TRIM INTER Switch - PRESS.
- (2) In case of Manual Electric Trim malfunction:
  - a. AP DISC/TRIM INTER Switch - PRESS and HOLD.
  - b. PITCH TRIM Circuit Breaker - PULL.
  - c. Aircraft - RETRIM manually.

**SECTION 4 - NORMAL PROCEDURES**

**(a) PREFLIGHT (PERFORM PRIOR TO EACH FLIGHT)**

- (1) **GYROS** - Allow 3-4 minutes for gyros to come up to speed.
- (2) **RADIO POWER / AVIONICS MASTER Switch** - ON
- (3) **PREFLIGHT TEST BUTTON** - PRESS momentarily and NOTE:
  - a. All annunciator lights on (TRIM annunciator flashing).
  - b. After approximately 5 seconds, all annunciator lights off except AP which will flash approximately 12 times and then remain off.

**NOTE**

If trim warning light stays on then the manual electric trim did not pass preflight test. The pitch trim circuit breaker should be pulled. The autopilot can still be used.

- (4) **MANUAL ELECTRIC TRIM** (if installed) - TEST as follows:
  - a. Actuate the left side of the split switch to the fore and aft positions. The trim wheel should not move on its own. Rotate the trim wheel manually against the engaged clutch to check the pilot's overpower capability.
  - b. Actuate right side of split switch unit to the fore and aft positions. The trim wheel should not move on its own and normal trim wheel force is required to move it manually.
  - c. Press the AP DISC/TRIM INTER switch down and hold. Manual Electric Trim should not operate either nose up or or nose down.
- (5) **AUTOPILOT** - ENGAGE by pressing AP ENG button.
- (6) **CONTROL WHEEL** - MOVE left and right to verify that the autopilot can be overpowered.
- (7) **AP DISC/TRIM INTER Switch** - PRESS. Verify that the autopilot disconnects and all modes are cancelled.
- (8) **TRIM** - SET to take off position.

**(b) AUTOPILOT OPERATION**

- (1) Before takeoff  
AP DISC/TRIM INTER Switch - PRESS.



- (2) **Autopilot Engagement**  
AP ENG Button - PRESS. Note AP annunciator on. If no other modes are selected the autopilot will operate in the wings level mode.
- (3) **Heading Changes**
  - a. **Manual Heading Changes**
    - 1. CWS Button - PRESS and MANEUVER aircraft to the desired heading.
    - 2. CWS Button - RELEASE. Autopilot will maintain aircraft in wings level attitude.

**NOTE**

Aircraft heading may change in the wings level mode due to an aircraft out of trim condition.

- b. **Heading Hold**
    - 1. Heading Selector Knob - SET BUG to desired heading.
    - 2. HDG Mode Selector Button - PRESS. Note HDG mode annunciator ON. Autopilot will automatically turn the aircraft to the selected heading.
  - c. **Command Turns (Heading Hold Mode ON)**  
HEADING Selector Knob - MOVE BUG to the desired heading. Autopilot will automatically turn the aircraft to the new selected heading.
- (4) **NAV Coupling**
  - a. **When equipped with HSI.**
    - 1. Course Bearing Pointer - SET to desired course.

**NOTE**

When equipped with NAV 1/NAV 2 switching and NAV 2 is selected, set OBS to the desired course.

- 2. HEADING SELECTOR KNOB - SET BUG to provide desired intercept angle.

**3. NAV Mode Selector Button - PRESS.**

If the Course Deviation Bar is greater than 2 to 3 dots: the aircraft will continue in HDG mode (or wings level if HDG not selected) with the NAV annunciator flashing; when the computed capture point is reached the HDG will disengage, the NAV annunciator will illuminate steady and the selected course will be automatically captured and tracked.

If the D-Bar is less than 2 to 3 dots: the HDG mode will disengage upon selecting NAV mode; the NAV annunciator will illuminate steady and the capture/track sequence will automatically begin.

**b. When equipped with DG**

- 1. OBS Knob - SELECT desired course.**
- 2. NAV Mode Selector Button - PRESS.**
- 3. Heading Selector Knob - ROTATE BUG to agree with OBS course.**

**NOTE**

When NAV is selected, the lateral operating mode will change from HDG (if selected) to wings level for 5 seconds. A 45° intercept angle will then be automatically established based on the position of the bug.

If the D-Bar is greater than 2 to 3 dots: the autopilot will announce HDG mode, (unless HDG not selected) and NAV flashing; when the computed capture point is reached the HDG annunciator will go out, the NAV annunciator will illuminate steady and the selected course will be automatically captured and tracked.

If the D-Bar is less than 2 to 3 dots: the HDG mode will disengage upon selecting NAV mode; the NAV annunciator will illuminate steady and the capture/track sequence will automatically begin.

- (5) Approach (APR) Coupling
  - a. When equipped with HSI
    - 1. Course Bearing Pointer - SET to desired course.

**NOTE**

When equipped with NAV 1/NAV 2 switching and NAV 2 is selected, set OBS to the desired course.

- 2. HEADING Selector Knob - SET BUG to provide desired intercept angle.
- 3. APR Mode Selector Button - PRESS.  
If the Course Deviation Bar is greater than 2 to 3 dots: the aircraft will continue in HDG mode (or wings level if HDG not selected) with the APR annunciator flashing; when the computed capture point is reached the HDG will disengage, the APR annunciator will illuminate steady and the selected course will be automatically captured and tracked.

If the D-Bar is less than 2 to 3 dots: the HDG mode will disengage upon selecting APR mode; the APR annunciator will illuminate steady and the capture/track sequence will automatically begin.

- b. When equipped with DG
  - 1. OBS Knob - SELECT desired approach course.
  - 2. APR Mode Selector Button - PRESS.
  - 3. Heading Selector Knob - ROTATE Bug to agree with OBS course.

**NOTE**

When APR is selected, the lateral operating mode will change from HDG (if selected) to wings level for 5 seconds. A 45° intercept angle will then be automatically established based on the position of the bug.

If the D-Bar is greater than 2 to 3 dots: the autopilot will annunciate HDG mode (unless HDG not selected) and APR flashing; when the computed capture point is reached the HDG annunciator will go out, the APR annunciator will illuminate steady and the selected course will be automatically captured and tracked

If the D-Bar is less than 2 to 3 dots: the HDG mode will disengage upon selecting APR mode; the APR annunciator will illuminate steady and the capture/track sequence will automatically begin.

(6) BC Approach Coupling

- a. When equipped with HSI
  1. Course Bearing Pointer - SET to the ILS front course inbound heading.

NOTE

When equipped with NAV 1/NAV 2 switching and NAV 2 is selected, set OBS to the ILS front course inbound heading.

2. HEADING Selector Knob - SET BUG to provide desired intercept angle.
3. BC Mode Selector Button - PRESS.

If the Course Deviation Bar is greater than 2 to 3 dots: the aircraft will continue in HDG mode (or wings level if HDG not selected) with BC annunciated steady and APR annunciator flashing; when the computed capture point is reached the HDG will disengage, the BC and APR annunciators will illuminate steady and the selected course will be automatically captured and tracked.

If the D-Bar is less than 2 to 3 dots: the HDG mode will disengage upon selecting BC mode; the APR BC annunciator will illuminate steady and the capture/track sequence will automatically begin.

- b. When equipped with DG
  - 1. OBS Knob - SELECT the ILS front course inbound heading.
  - 2. BC Mode Selector Button - PRESS.
  - 3. Heading Selector Knob - ROTATE Bug to the ILS front course inbound heading.

**NOTE**

When BC is selected, the lateral operating mode will change from HDG (if selected) to wings level for 5 seconds. A 45° intercept angle will then be established based on the position of the bug.

If the D-Bar is greater than 2 to 3 dots: the autopilot will annunciate HDG (unless HDG not selected) and BC modes with APR flashing; when the computed capture point is reached the HDG annunciator will go out, the BC and APR annunciators will illuminate steady and the selected course will be automatically captured and tracked.

If the D-Bar is less than 2 to 3 dots: the HDG mode will disengage upon selecting BC mode; the BC and APR annunciators will illuminate steady and the capture/track sequence will automatically begin.

- (7) Missed Approach
  - a. AP DISC/TRIM INTER - PRESS to disengage AP.
  - b. MISSED APPROACH - EXECUTE.
  - c. AP ENG Button - PRESS (if AP operation is desired).  
Note AP annunciator ON.

- (8) Before Landing  
AP DISC/TRIM INTER - PRESS to disengage AP.

**SECTION 5 - PERFORMANCE**

No change.

## **SECTION 6 - WEIGHT AND BALANCE**

Factory installed optional equipment is included in the licensed weight and balance data in Section 6 of the Basic Pilot's Operating Handbook.

## **SECTION 7 - DESCRIPTION AND OPERATION**

This manual is provided to acquaint the pilot with the limitations as well as normal and emergency operating procedures of the King KAP 100 Automatic Flight Control System. The limitations presented are pertinent to the operation of the KAP 100 System as installed in the Piper Model PA-28-181 airplane; the Flight Control System must be operated within the limitations herein specified.

The KAP 100 Autopilot is certified in this airplane with roll axis control. The various instruments and the controls for the operation of the KAP 100 Autopilot are described in Figures 7-1 thru 7-11.

The KAP 100 Autopilot has an optional electric pitch trim system. The trim system is designed to withstand any single inflight malfunction. A trim fault is visually and aurally annunciated.

A lockout device prevents autopilot engagement until the system has been successfully preflight tested.

The following conditions will cause the Autopilot to automatically disengage:

- (a) Power failure.
- (b) Internal Flight Control System failure.
- (c) With the KCS 55A Compass System, a loss of compass valid (displaying HDG flag) disengages the Autopilot when a mode using heading information is engaged. With the HDG flag present only the autopilot wings level mode can be selected.
- (d) Roll rates in excess of  $16^{\circ}$  per second will cause the autopilot to disengage except when the CWS switch is held depressed.

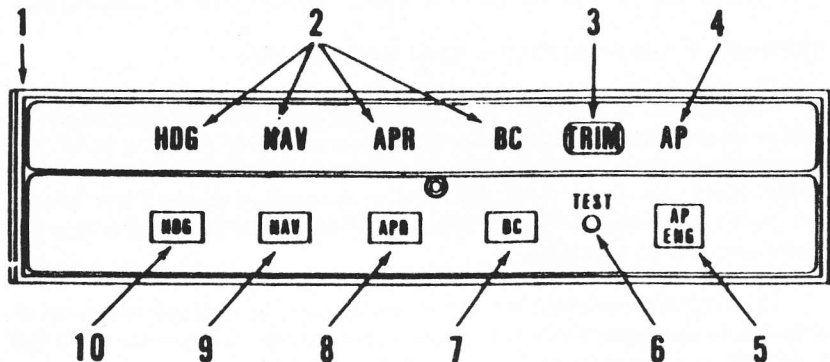

### KC 190 AUTOPILOT COMPUTER

Figure 7-1

1. **KAP 100 AUTOPILOT COMPUTER** - Complete Autopilot computer to include system mode annunciators and system controls.
2. **MODE ANNUNCIATORS** - Illuminate when a mode is selected by the corresponding mode selector button (PUSH ON - PUSH OFF).
3. **TRIM WARNING LIGHT (TRIM)** - Illuminates continuously whenever trim power is not on or the system has not been pre-flight tested. The TRIM warning light, will flash and be accompanied by an audible warning whenever a manual pitch trim malfunction occurs (trim running without being commanded to run).
4. **AUTOPILOT ANNUNCIATOR (AP)** - Illuminates continuously whenever the autopilot is engaged. Flashes approximately 12 times whenever the autopilot is disengaged (an aural alert will also sound for 2 seconds).
5. **AUTOPILOT ENGAGE (AP ENG) BUTTON** - When pushed, engages autopilot if all logic conditions are met.

Figure 7-1 (cont)

6. **PREFLIGHT TEST (TEST) BUTTON** - When momentarily pushed, initiates preflight test sequence which automatically turns on all annunciator lights, tests the roll rate monitor, checks the manual trim drive voltage, checks the manual electric trim monitor and tests all autopilot valid and dump logic. If the preflight is successfully passed, the AP annunciator light will flash for approximately 6 seconds (an aural tone will also sound simultaneously with the annunciator flashes). The autopilot cannot be engaged until the preflight test is successfully passed.
7. **BACK COURSE APPROACH (BC) MODE SELECTOR BUTTON** - When pushed, will select the Back Course Approach mode. This mode functions identically to the approach mode except that response to LOC signals is reversed.
8. **APPROACH (APR) MODE SELECTOR BUTTON** - When pushed, will select the Approach mode. This mode provides all angle intercept (with HSI) or a fixed angle intercept of 45° (with DG), automatic beam capture and tracking of VOR, RNAV or LOC signals. The tracking gain of the APR mode is greater than the gain in the NAV mode. The APR annunciator will flash until the automatic capture sequence is initiated.
9. **NAVIGATION (NAV) MODE SELECTOR BUTTON** - When pushed, will select the Navigation mode. The mode provides all angle intercept (with HSI) or a fixed angle intercept of 45° (with DG), automatic beam capture and tracking of VOR, RNAV or LOC signals. The NAV annunciator will flash until the automatic capture sequence is initiated.
10. **HEADING (HDG) MODE SELECTOR BUTTON** - When pushed, will select the Heading mode, which commands the airplane to turn to and maintain the heading selected by the heading bug on the DG or HSI. A new heading may be selected at any time and will result in the airplane turning to the new heading with a maximum bank angle of about 20°. Selecting HDG mode will cancel NAV, APR or BC track modes.



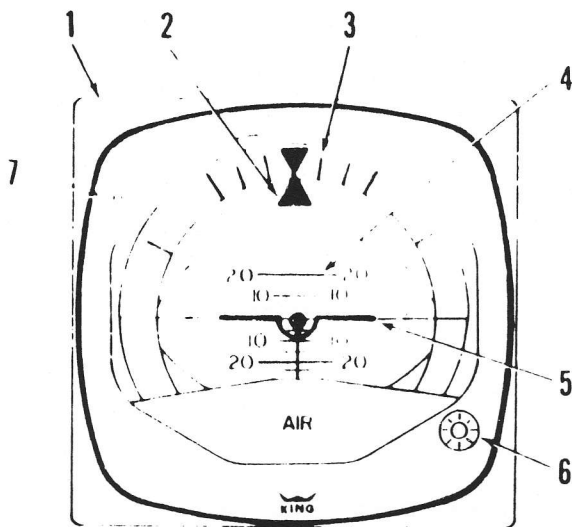

**KG 258 VERTICAL GYRO**

Figure 7-3

1. **KG 258 VERTICAL GYRO** - Displays airplane attitude as a conventional attitude gyro. The gyro is air driven.
2. **ROLL ATTITUDE INDEX** - Displays airplane roll attitude with respect to the roll attitude scale.
3. **ROLL ATTITUDE SCALE** - Scale marked at 0,  $\pm 10$ ,  $\pm 20$ ,  $\pm 30$ ,  $\pm 60$  and  $\pm 90$  degrees.
4. **PITCH ATTITUDE SCALE** - Moves with respect to the symbolic airplane to present pitch attitude. Scale graduated at 0,  $\pm 5$ ,  $\pm 10$ ,  $\pm 15$ ,  $\pm 20$  and  $\pm 25$  degrees.
5. **SYMBOLIC AIRPLANE** - Serves as a stationary symbol of the aircraft. Aircraft pitch and roll attitudes are displayed by the relationship between the fixed symbolic aircraft and the movable background.
6. **SYMBOLIC AIRCRAFT ALIGNMENT KNOB** - Provides manual positioning of the symbolic aircraft for level flight under various load conditions.
7. **DECISION HEIGHT (DH) ANNUNCIATOR LIGHT** - Optional light for use with the aircraft's optional radar altimeter.

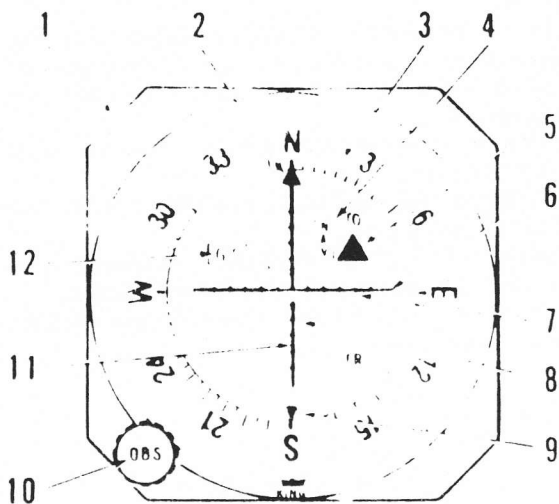

**KI 204/206 VOR/LOC/  
GLIDE SLOPE INDICATOR (TYPICAL)**

Figure 7-5

1. **VOR/LOC/GLIDE SLOPE INDICATOR** - Provides rectilinear display of VOR/LOC and Glide slope deviation.
2. **COURSE INDEX** - Indicates selected VOR course.
3. **COURSE CARD** - Indicates selected VOR course under course index.
4. **NAV FLAG** - Flag is in view when the NAV receiver signal is inadequate. When a NAV flag is present in the navigation indicator (CDI or KI 525A) the autopilot operation is not affected. The pilot must monitor the navigation indicators for NAV flags to insure that the Autopilot is tracking valid navigation information.
5. **TO/FROM INDICATOR FLAG** - Indicates direction of VOR station relative to selected course.
6. **GLIDE SLOPE DEVIATION NEEDLE** - Indicates deviation from 11 S glide slope.
7. **COURSE DEVIATION SCALE** - A course deviation bar displacement of 5 dots represents full scale (VOR =  $\pm 10^\circ$ , LOC =  $\pm 1.2^\circ$ , RNAV = 5NM, RNAV APR = 1 1/4NM) deviation from beam centerline.

Figure 7-5 (cont)

8. GLIDE SLOPE SCALE - Indicates displacement from glide slope beam center. A glide slope deviation needle displacement of 5 dots, represents full scale ( $0.7^\circ$ ) deviation above or below glide slope beam centerline.
9. RECIPROCAL COURSE INDEX - Indicates reciprocal of selected VOR course.
10. OMNI BEARING SELECTOR (OBS) KNOB - Rotates course card to selected course.
11. COURSE DEVIATION NEEDLE - Indicates course deviation from selected omni course or localizer centerline.
12. GLIDE SLOPE (GS) FLAG - Flag is in view when the GS receiver signal is inadequate.

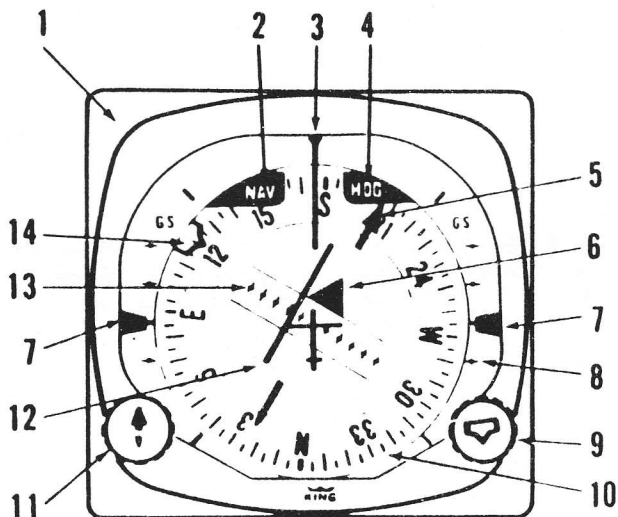

KI 525A HORIZONTAL SITUATION INDICATOR

Figure 7-7

Figure 7-7 (cont)



1. **KI 525A HORIZONTAL SITUATION INDICATOR (HSI)** - Provides a pictorial presentation of aircraft deviation relative to VOR radials or localizer beams. It also displays glide slope deviations and gives heading reference with respect to magnetic north.
2. **NAV FLAG** - Flag is in view when the NAV receiver signal is inadequate. When a NAV flag is present in the navigation indicator (CDI or KI 525A) the autopilot operation is not affected. The pilot must monitor the navigation indicators for NAV flags to insure that the Autopilot is tracking valid navigation information.
3. **LUBBER LINE** - Indicates aircraft magnetic heading on compass card (10).
4. **HEADING WARNING FLAG (HDG)** - When flag is in view the heading display is invalid. If a HDG flag appears and a lateral mode (HDG, NAV, APR or APR BC) is selected, the Autopilot will be disengaged. The Autopilot may be re-engaged in the basic wings level mode. The CWS switch would be used manually to maneuver the aircraft laterally.
5. **COURSE BEARING POINTER** - Indicates selected VOR course or localizer course on compass card (10). The selected VOR radial or localizer heading remains set on the compass card when the compass card (10) rotates.
6. **TO/FROM INDICATOR FLAG** - Indicates direction of VOR station relative to selected course.
7. **DUAL GLIDE SLOPE POINTERS** - Indicate on glide slope scale (8) aircraft displacement from glide slope beam center. Glide slope pointers in view indicate a usable glide slope signal is being received.
8. **GLIDE SLOPE SCALES** - Indicate displacement from glide slope beam center. A glide slope deviation bar displacement of 2 dots, represents full scale (0.7°) deviation above or below glide slope beam centerline.
9. **HEADING SELECTOR KNOB (  )** - Positions heading Bug (14) on compass card (10) by rotating the heading selector knob. The Bug rotates with the compass card.
10. **COMPASS CARD** - Rotates to display heading of airplane with reference to lubber line (3).
11. **COURSE SELECTOR KNOB** - Positions course bearing pointer (5) on the compass card (10) by rotating the course selector knob.
12. **COURSE DEVIATION BAR (D-BAR)** - The center portion of omni bearing pointer moves laterally to pictorially indicate the relationship of aircraft to selected course. It indicates in degrees of angular displacement from VOR radials and localizer beams or displacement in nautical miles from RNAV courses.

Figure 7-7 (cont)



- 13. COURSE DEVIATION SCALE - A course deviation bar displacement of 5 dots represents full scale (VOR =  $\pm 10^\circ$ , LOC =  $\pm 2 \frac{1}{2}^\circ$ , RNAV = 5NM, RNAV APR -  $1 \frac{1}{4}$ NM) deviation from beam centerline.
- 14. HEADING BUG - Moved by (  ) knob (9) to select desired heading.

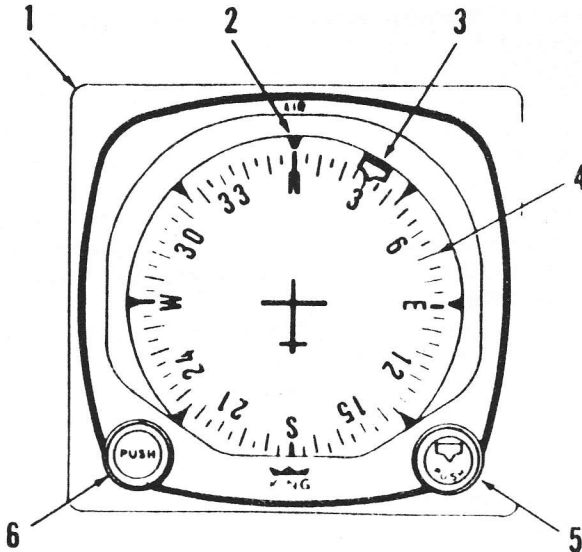

KG 107 NON-SLAVED DIRECTIONAL GYRO

Figure 7-9

Figure 7-9 (cont)

1. KG 107 NON-SLAVED DIRECTIONAL GYRO (DG) - Provides a stable visual indication of aircraft heading to the pilot. The gyro is air driven.
2. LUBBER LINE - Indicates aircraft magnetic heading on compass card (4).
3. HEADING BUG - Moved by (  ) knob (5) to select desired heading.
4. COMPASS CARD - Rotates to display heading of airplane with reference to lubber line (2).
5. HEADING SELECTOR KNOB (  ) - Positions heading Bug (3) on compass card (4) by rotating the heading selector knob. The Bug rotates with the compass card.
6. GYRO ADJUSTMENT KNOB (PUSH) - When pushed in, allows the pilot to manually rotate the gyro compass card (4) to correspond with the magnetic heading indicated by the magnetic compass. The unslaved compass card must be manually reset periodically to compensate for precessional errors in the gyro.

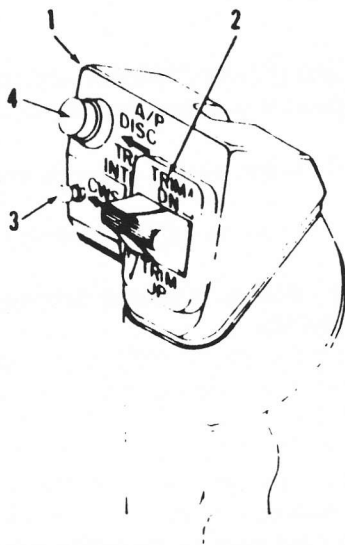

### AUTOPILOT CONTROL WHEEL SWITCH CAP

Figure 7-11

1. **AUTOPILOT CONTROL WHEEL SWITCH CAP** - Molded plastic unit mounted on the left horn of the pilot's control wheel which provides mounting for three switch units associated with the autopilot and manual electric trim systems (only used with optional manual electric trim).
2. **MANUAL ELECTRIC TRIM CONTROL SWITCHES** - A split switch unit in which the left half provides power to engage the trim servo clutch and the right half to control the direction of motion of the trim servo motor. Both halves of the split trim switch must be actuated in order for the manual trim to operate in the desired direction.
3. **CONTROL WHEEL STEERING (CWS) BUTTON** - When depressed, allows pilot to manually control the aircraft (disengages the servo) without cancellation of any of the selected modes.
4. **AUTOPILOT DISCONNECT/TRIM INTERRUPT (AP DISC/TRIM INT) Switch** - When depressed and released, will disengage the autopilot and cancel all operating autopilot modes. When depressed and held, will interrupt all electric trim power (stop trim motion), disengage the autopilot, and cancel all operating autopilot modes.

The airplane MASTER SWITCH function is unchanged and can be used in an emergency to shut off electrical power to all flight control systems while the problem is isolated.

The RADIO POWER switch supplies power to the avionics bus bar of the radio circuit breakers and the autopilot circuit breaker.

The following circuit breakers are used to protect the following elements of the King KAP 100 Autopilot:

**AUTOPHLOT** - Supplies power to the KC 190, the autopilot roll servo, and the Pitch Trim Circuit Breaker.

**PITCH TRIM** - Supplies power to the optional manual electric pitch trim system.

**COMP-SYSTEM** - Supplies power to the optional KCS 55A Compass System.



THIS PAGE INTENTIONALLY LEFT BLANK

**PILOT'S OPERATING HANDBOOK  
AND  
FAA APPROVED AIRPLANE FLIGHT MANUAL  
SUPPLEMENT NO. 8  
FOR  
KING KAP 150 SERIES FLIGHT CONTROL SYSTEM**

This supplement must be attached to the Pilot's Operating Handbook and FAA Approved Airplane Flight Manual when the King KAP 150 Series Flight Control System is installed in accordance with STC SA1565CE-D. The information contained herein supplements or supersedes the information in the basic Pilot's Operating Handbook and FAA Approved Airplane Flight Manual only in those areas listed herein. For limitations, procedures and performance information not contained in this supplement, consult the basic Pilot's Operating Handbook and FAA Approved Airplane Flight Manual.

FAA APPROVED Ward Evans  
WARD EVANS  
D.O.A. NO. SO-1  
PIPER AIRCRAFT CORPORATION  
VERO BEACH, FLORIDA

DATE OF APPROVAL JULY 21, 1982

## **SECTION 1 - GENERAL**

This supplement supplies information necessary for the operation of the airplane when the optional King KAP 150 Series Flight Control System is installed. The Flight Control System must be operated within the limitations herein specified. The information contained within this supplement is to be used in conjunction with the complete handbook.

This supplement has been FAA Approved as a permanent part of this handbook and must remain in this handbook at all times when the optional King KAP 150 Series Flight Control System is installed.

## **SECTION 2 - LIMITATIONS**

- (a) During autopilot operation, a pilot with seat belt fastened must be seated at the left pilot position.
- (b) The autopilot must be OFF during takeoff and landing.
- (c) The system is approved for Category I operation only (Approach mode selected).
- (d) Autopilot airspeed limitation: Maximum 135 KIAS.

### **NOTE**

In accordance with FAA recommendation, use of "altitude hold" mode is not recommended during operation in severe turbulence.

## **SECTION 3 - EMERGENCY PROCEDURES**

- (a) In case of Autopilot malfunction: (accomplish items 1. and 2. simultaneously)
  - (1) Airplane Control Wheel - GRASP FIRMLY and regain aircraft control.
  - (2) AP DISC/TRIM INTER Switch - PRESS and HOLD.
  - (3) AP DISC/TRIM INTER Switch - RELEASE while observing pitch trim wheel. If pitch trim wheel is in motion, follow the Electric Trim Malfunction Procedure.

(b) In case of Electric Trim Malfunction (either manual electric or autotrim):

- (1) AP DISC/TRIM INTER Switch - PRESS and HOLD throughout recovery.
- (2) PITCH TRIM Circuit Breaker - PULL.
- (3) Aircraft - RETRIM manually.

**CAUTION**

When disconnecting the autopilot after a trim malfunction, hold the control wheel firmly; up to 45 pounds of force on the control wheel may be necessary to hold the aircraft level.

Maximum Altitude losses due to autopilot malfunction:

Configuration	Alt Loss
Cruise, Climb, Descent	310'
Maneuvering	90'
APPR	85'

**SECTION 4 - NORMAL PROCEDURES**

(a) PREFLIGHT (PERFORM PRIOR TO EACH FLIGHT)

- (1) GYROS - Allow 3-4 minutes for gyros to come up to speed.
- (2) RADIO POWER /AVIONICS MASTER Switch - ON.
- (3) PREFLIGHT TEST BUTTON - PRESS momentarily and NOTE:
  - a. All annunciator lights on (TRIM annunciator flashing).
  - b. After approximately 5 seconds, all annunciator lights off except AP which will flash approximately 12 times and then remain off.

**NOTE**

If trim warning light stays on then the autotrim did not pass preflight test. The autopilot circuit breakers should be pulled. Manual electric trim cannot be used.

- (4) **MANUAL ELECTRIC TRIM - TEST** as follows:
  - a. Actuate the left side of the split switch to the fore and aft positions. The trim wheel should not move on its own. Rotate the trim wheel manually against the engaged clutch, to check the pilot's overpower capability.
  - b. Actuate right side of split switch unit to the fore and aft positions. The trim wheel should not move on its own and normal trim wheel force is required to move it manually.
  - c. Press the AP DISC/TRIM INTER switch down and hold. Manual Electric Trim should not operate either nose up or nose down.
- (5) **FLIGHT DIRECTOR (KFC 150 ONLY) - ENGAGE** by pressing FD or CWS button.
- (6) **AUTOPILOT - ENGAGE** by pressing AP ENG button.
- (7) **CONTROL WHEEL - MOVE** fore, aft, left and right to verify that the autopilot can be overpowered.
- (8) **AP DISC/TRIM INTER Switch - PRESS.** Verify that the autopilot disconnects and all flight director modes are cancelled.
- (9) **TRIM - SET** to take off position.

**(b) AUTOPILOT OPERATION**

- (1) **Before takeoff**  
AP DISC/TRIM INTER Switch - PRESS.
- (2) **Autopilot Engagement**
  - a. **FD Mode Selector Button (KFC 150 Only) - PRESS.**
  - b. **AP ENG Button - PRESS.** Note AP annunciator on. If no other modes are selected the autopilot will operate in wings level and pitch attitude hold.
- (3) **Climb or Descent**
  - a. **Using CWS**
    1. **CWS Button - PRESS** and MOVE aircraft nose to the desired attitude.
    2. **CWS Button - RELEASE.** Autopilot will maintain aircraft pitch attitude up to the pitch limits of +15° or -10°.

- b. Using Vertical Trim
    - 1. **VERTICAL TRIM Control - PRESS** either up or down to modify aircraft attitude at a rate of .7 deg/sec. up to the pitch limits of +15° or -10°.
    - 2. **VERTICAL TRIM Control - RELEASE** when desired aircraft attitude is reached. The autopilot will maintain the desired pitch attitude.
- (4) Altitude Hold
- a. **ALT Mode Selector Button - PRESS.** Note **ALT** mode annunciator **ON**. Autopilot will maintain the selected pressure altitude.
  - b. Change selected altitudes
    - 1. Using **CWS** (recommended for altitude changes greater than 100 ft.)  
**CWS Button - PRESS** and fly aircraft to desired pressure altitude.  
  
**CWS Button - RELEASE** when desired pressure altitude is reached. The autopilot will maintain the desired pressure altitude.
    - 2. Using Vertical Trim (Recommended for altitude changes less than 100 ft.)  
**VERTICAL TRIM Control - PRESS** either up or down. Vertical Trim will seek an altitude rate of change of 600 ± 100 fpm.  
  
**VERTICAL TRIM Control - RELEASE** when desired pressure altitude is reached. The autopilot will maintain the desired pressure altitude.
- (5) Heading Changes
- a. Manual Heading Changes
    - 1. **CWS Button - PRESS** and **MANEUVER** aircraft to the desired heading.
    - 2. **CWS Button - RELEASE.** Autopilot will maintain aircraft in wings level attitude.

**NOTE**

Aircraft heading may change in the wings level mode due to an aircraft out of trim condition.

- b. **Heading Hold**
    - 1. **Heading Selector Knob - SET BUG** to desired heading.
    - 2. **HDG Mode Selector Button - PRESS.** Note HDG mode annunciator ON. Autopilot will automatically turn the aircraft to the selected heading.
  
  - c. **Command Turns (Heading Hold mode ON)**  
**HEADING Selector Knob - MOVE BUG** to the desired heading. Autopilot will automatically turn the aircraft to the new selected heading.
- (6) **NAV Coupling**
- a. **When equipped with HSI.**
    - 1. **Course Bearing Pointer - SET** to desired course.

**NOTE**

When equipped with NAV 1/NAV 2 switching and NAV 2 is selected, set OBS to the desired course.

- 2. **HEADING Selector Knob - SET BUG** to provide desired intercept angle.
- 3. **NAV Mode Selector Button - PRESS.**  
If the Course Deviation Bar is greater than 2 to 3 dots: the aircraft will continue in HDG mode (or wings level if HDG not selected) with the NAV annunciator flashing; when the computed capture point is reached the HDG will disengage, the NAV annunciator will illuminate steady and the selected course will be automatically captured and tracked.

If the D-Bar is less than 2 to 3 dots: the HDG mode will disengage upon selecting NAV mode; the NAV annunciator will illuminate steady and the capture/track sequence will automatically begin.

- b. **When equipped with DG**
  - 1. **OBS Knob - SELECT** desired course.
  - 2. **NAV Mode Selector Button - PRESS.**

3. Heading Selector Knob - ROTATE BUG to agree with OBS course.

**NOTE**

When NAV is selected, the lateral operating mode will change from HDG (if selected) to wings level for 5 seconds. A 45° intercept angle will then be automatically established based on the position of the bug.

If the D-Bar is greater than 2 to 3 dots: the autopilot will annunciate HDG mode and NAV flashing; when the computed capture point is reached the HDG annunciator will go out, the NAV annunciator will illuminate steady and the selected course will be automatically captured and tracked.

If the D-Bar is less than 2 to 3 dots: the HDG mode will disengage upon selecting NAV mode; the NAV annunciator will illuminate steady and the capture/track sequence will automatically begin.

- (7) Approach (APR) Coupling
  - a. When equipped with HSI
    1. Course Bearing Pointer - SET to desired course.

**NOTE**

When equipped with NAV 1/NAV 2 switching and NAV 2 is selected, set OBS to the desired course.

2. HEADING Selector Knob - SET BUG to provide desired intercept angle.
3. APR Mode Selector Button - PRESS.

If the Course Deviation Bar is greater than 2 to 3 dots: the aircraft will continue in HDG mode (or wings level if HDG not selected) with the APR annunciator flashing; when the computed capture point is reached the HDG will disengage, the APR annunciator will illuminate steady and the selected course will be automatically captured and tracked.



If the D-Bar is less than 2 to 3 dots: the HDG mode will disengage upon selecting APR mode; the APR annunciator will illuminate steady and the capture/track sequence will automatically begin.

- b. When equipped with DG
  - 1. OBS Knob - SELECT desired approach course.
  - 2. APR Mode Selector Button - PRESS.
  - 3. Heading Selector Knob - ROTATE Bug to agree with OBS course.

**NOTE**

When APR is selected, the lateral operating mode will change from HDG (if selected) to wings level for 5 seconds. A 45° intercept angle will then be automatically established based on the position of the bug.

If the D-Bar is greater than 2 to 3 dots: the autopilot will annunciate HDG mode (unless HDG not selected) and APR flashing; when the computed capture point is reached the HDG annunciator will go out, the APR annunciator will illuminate steady and the selected course will be automatically captured and tracked.

If the D-Bar is less than 2 to 3 dots: the HDG mode will disengage upon selecting APR mode; the APR annunciator will illuminate steady and the capture/track sequence will automatically begin.

- (8) BC Approach Coupling
  - a. When equipped with HSI
    - 1. Course Bearing Pointer - SET to the ILS front course inbound heading.

**NOTE**

When equipped with NAV 1/NAV 2 switching and NAV 2 is selected, set OBS to the ILS front course inbound heading.

2. **HEADING Selector Knob - SET BUG** to provide desired intercept angle.
3. **BC Mode Selector Button - PRESS.**  
If the Course Deviation Bar is greater than 2 to 3 dots: the aircraft will continue in HDG mode (or wings level if HDG not selected) with BC annunciated steady and APR annunciator flashing; when the computed capture point is reached the HDG will disengage, and the BC and APR annunciators will illuminate steady and the selected course will be automatically captured and tracked.

If the D-Bar is less than 2 to 3 dots: the HDG mode will disengage upon selecting BC mode; the APR BC annunciator will illuminate steady and the capture/track sequence will automatically begin.

- b. **When equipped with DG**
  1. **OBS Knob - SELECT** the ILS front course inbound heading.
  2. **BC Mode Selector Button - PRESS.**
  3. **Heading Selector Knob - ROTATE Bug** to the ILS front course inbound heading.

#### **NOTE**

When BC is selected, the lateral operating mode will change from HDG (if selected) to wings level for 5 seconds. A 45° intercept angle will then be established based on the position of the bug.

If the D-Bar is greater than 2 to 3 dots: the autopilot will annunciate HDG (unless HDG not selected) and BC modes with APR flashing; when the computed capture point is reached the HDG annunciator will go out, the BC and APR annunciators will illuminate steady and the selected course will be automatically captured and tracked.

If the D-Bar is less than 2 to 3 dots: the HDG mode will disengage upon selecting BC mode; the BC and APR annunciators will illuminate steady and the capture/track sequence will automatically begin.

**(9) Glide Slope Coupling**

**NOTE**

Glide slope coupling is inhibited when operating in NAV or APR BC modes. Glide slope coupling occurs automatically in the APR mode.

- a. APR Mode - ENGAGED.
- b. At glide slope centering - NOTE GS annunciator ON.

**NOTE**

Autopilot can capture glide slope from above or below the beam while operating in either pitch attitude hold or ALT hold modes.

**(10) Missed Approach**

- a. AP DISC/TRIM INTER Switch - PRESS to disengage AP.
- b. MISSED APPROACH - EXECUTE.
- c. CWS Button - PRESS (KFC 150 only) as desired to activate FD mode during go-around maneuver.
- d. AP ENG Button - PRESS (if AP operation is desired). Note AP annunciator ON.

**NOTE**

If it is desired to track the ILS course outbound as part of the missed approach procedure, use the NAV mode to prevent inadvertent GS coupling.

- (11) Before Landing  
AP DISC/TRIM INTER Switch - PRESS to disengage AP.
- (c) FLIGHT DIRECTOR OPERATION (KFC 150 SYSTEMS ONLY)

**NOTE**

The flight director modes of operation are the same as those used for autopilot operations except the autopilot is not engaged and the pilot must maneuver the aircraft to satisfy the flight director commands.

**SECTION 5 - PERFORMANCE**

No change.

**SECTION 6 - WEIGHT AND BALANCE**

Factory installed optional equipment is included in the licensed weight and balance data in Section 6 of the basic Pilot's Operating Handbook.

**SECTION 7 - DESCRIPTION AND OPERATION**

The 150 Series AFCS is certified in this airplane with 2 axis control, pitch and roll. The various instruments and the controls for the operation of the 150 System are described in Figures 7-1 thru 7-15.

The 150 Series AFCS has an electric pitch trim system which provides autotrim during autopilot operation and manual electric trim for the pilot. The trim system is designed to withstand any single inflight malfunction. Trim faults are visually and aurally annunciated.

A lockout device prevents autopilot engagement until the system has been successfully preflight tested.

The following conditions will cause the Autopilot to automatically disengage:

- (a) Power failure.
- (b) Internal Flight Control System failure.
- (c) With the KCS 55A Compass System, a loss of compass valid (displaying HDG flag) disengages the Autopilot when a mode using heading information is engaged. With the HDG flag present, the Autopilot may be re-engaged in the basic wings level mode along with any vertical mode.
- (d) Roll rates in excess of 16° per second will cause the autopilot to disengage except when the CWS switch is held depressed.
- (e) Pitch rates in excess of 6° per second will cause the autopilot to disengage except when the CWS switch is held depressed.

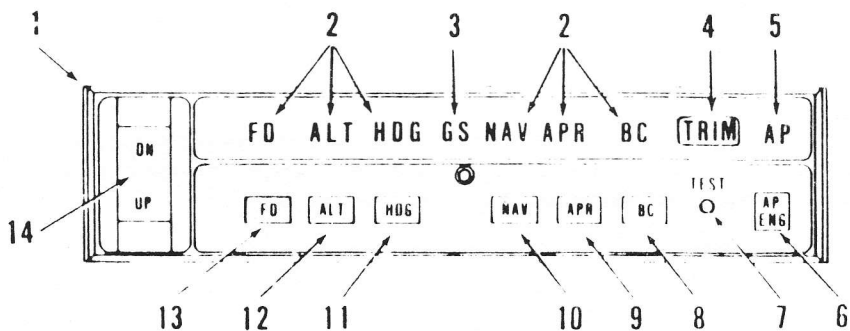

KC 192 AUTOPILOT & FLIGHT DIRECTOR COMPUTER  
Figure 7-1

1. KFC 150 SYSTEM KC 192 AUTOPILOT COMPUTER - Complete Flight Director and Autopilot computer to include system mode annunciators and system controls.
2. MODE ANNUNCIATORS - Illuminates when a mode is selected by the corresponding mode selector button (PUSH ON - PUSH OFF) or when the glide slope (GS) mode is automatically engaged.
3. GLIDE SLOPE (GS) ANNUNCIATOR - Illuminates continuously whenever the autopilot is coupled to the glide slope signal. The GS annunciator will flash if the glide slope signal is lost (GS flag in CDI or absence of glide slope pointers in KI 525A). The autopilot reverts to pitch attitude hold operation. If a valid glide slope signal returns within six seconds, the autopilot will automatically recouple in the GS mode. If the valid signal does not return within six seconds, the autopilot will remain in pitch attitude hold mode until such time that a valid glide slope returns and the aircraft passes thru the glide slope. At that point GS couple will re-occur.
4. TRIM WARNING LIGHT (TRIM) - Illuminates continuously whenever trim power is not on or the system has not been preflight tested. The TRIM warning light flashes and is accompanied by an audible warning whenever a manual trim fault is detected. The TRIM warning light will illuminate steady and be accompanied by a steady audible tone whenever an autotrim failure occurs. The autotrim system is monitored for the following failures: trim servo running without a command; trim servo not running when commanded to run; trim servo running in the wrong direction. The trim circuit breaker may be cycled off to silence the continuous tone but the trim fail light will remain on. The manual electric trim may be used but the autopilot should not be engaged.
5. AUTOPILOT ANNUNCIATOR (AP) - Illuminates continuously whenever the autopilot is engaged. Flashes approximately 12 times whenever the autopilot is disengaged (an aural alert will also sound for 2 seconds).
6. AUTOPILOT ENGAGE (AP ENG) BUTTON - When pushed, engages autopilot if all logic conditions are met.
7. PREFLIGHT TEST (TEST) BUTTON - When momentarily pushed, initiates preflight test sequence which automatically turns on all annunciator lights, tests the roll and pitch rate monitors, tests the autotrim fault monitor, checks the manual trim drive voltage and tests all autopilot valid and dump logic. If the preflight is successfully passed, the AP annunciator light will flash for approximately 6 seconds (an aural tone will also sound simultaneously with the annunciator flashes). The autopilot cannot be engaged until the autopilot preflight tests are successfully passed.

Figure 7-1 (cont)

8. **BACK COURSE APPROACH (BC) MODE SELECTOR BUTTON** - When pushed, will select the Back Course Approach mode. This mode functions identically to the approach mode except that response to LOC signals is reversed. Glide slope coupling is inhibited in the Back Course Approach mode.
9. **APPROACH (APR) MODE SELECTOR BUTTON** - When pushed, will select the Approach mode. This mode provides all angle intercept (with HSI) or a fixed angle intercept of 45° (with DG), automatic beam capture and tracking of VOR, RNAV or LOC signals plus glide slope coupling in the case of an ILS. The tracking gain of the APR mode is greater than the gain in the NAV mode. The APR annunciator will flash until the automatic capture sequence is initiated.
10. **NAVIGATION (NAV) MODE SELECTOR BUTTON** - When pushed, will select the Navigation mode. The mode provides all angle intercept (with HSI) or a fixed angle intercept of 45° (with DG), automatic beam capture and tracking of VOR, RNAV or LOC signals. The NAV annunciator will flash until the automatic capture sequence is initiated.
11. **HEADING (HDG) MODE SELECTOR BUTTON** - When pushed, will select the Heading mode, which commands the airplane to turn to and maintain the heading selected by the heading bug on the DG or HSI. A new heading may be selected at any time and will result in the airplane turning to the new heading with a maximum bank angle of about 20°. Selecting HDG mode will cancel NAV, APR or BC track modes.
12. **ALTITUDE HOLD (ALT) MODE SELECTOR BUTTON** - When pushed, will select the Altitude Hold mode, which commands the airplane to maintain the pressure altitude existing at the moment of selection. Engagement may be accomplished in climb, descent, or level flight. In the APR mode, altitude hold will automatically disengage when the glide slope is captured.
13. **FLIGHT DIRECTOR (FD) MODE SELECTOR BUTTON** - When pushed, will select the Flight Director mode (with KC 192 Autopilot Computer only), bringing the Command Bar in view on the K1 256 and will command wings level and pitch attitude hold. The FD mode must be selected prior to Autopilot engagement.
14. **VERTICAL TRIM CONTROL** - A spring loaded to center rocker switch which will provide up or down pitch command changes: while in ALT will adjust altitude at rate of about 500 fpm; when not in ALT will adjust pitch attitude at a rate of .7 deg/sec. Will cancel GS couple. The aircraft must pass through the glide slope again to allow GS recouple.

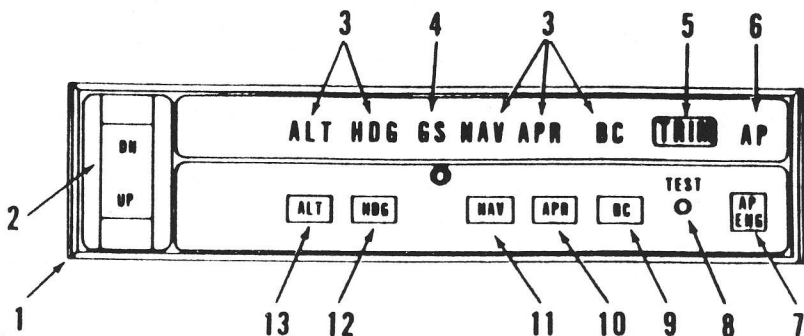

### KC 191 AUTOPILOT COMPUTER

Figure 7-3

1. KFC 150 SYSTEM KC 191 AUTOPILOT COMPUTER - Complete Autopilot computer. Includes system mode annunciators and system controls.
2. VERTICAL TRIM CONTROL - A spring loaded to center rocker switch which will provide up or down pitch command changes: while in ALT will adjust altitude at rate of about 500 fpm; when not in ALT will adjust pitch attitude at a rate of .7 deg/sec. Will cancel GS couple. The aircraft must pass through the glide slope again to allow GS recouple.
3. MODE ANNUNCIATORS - Illuminate when a mode is selected by the corresponding mode selector button (PUSH ON - PUSH OFF) or when the glide slope (GS) mode is automatically engaged.
4. GLIDE SLOPE (GS) ANNUNCIATOR - Illuminates continuously whenever the autopilot is coupled to the glide slope signal. The GS annunciator will flash if the glide slope signal is lost (GS flag in CDI or absence of glide slope pointers in KI 525A). The autopilot reverts to pitch attitude hold operation. If a valid glide slope signal returns within six seconds, the autopilot will automatically recouple in the GS mode. If the valid signal does not return within six seconds, the autopilot will remain in pitch attitude hold mode until such time that a valid glide slope returns and the aircraft passes thru the glide slope. At that point GS couple will re-occur.

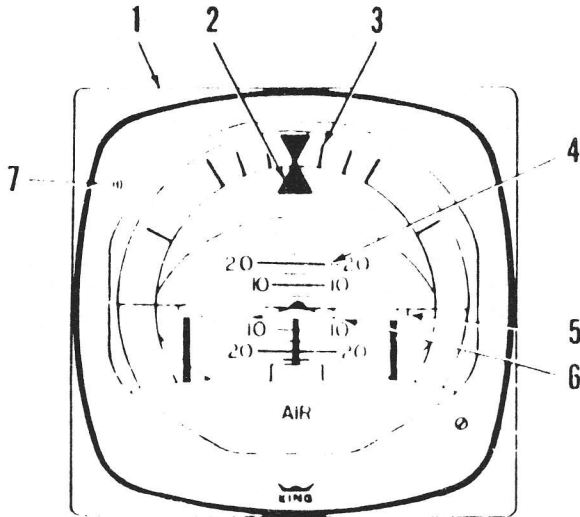

Figure 7-3 (cont)

5. **TRIM WARNING LIGHT (TRIM)** - Illuminates continuously whenever trim power is not on or the system has not been preflight tested. The TRIM warning light flashes and is accompanied by an audible warning whenever a manual trim fault is detected. The TRIM warning light will illuminate steady and be accompanied by a steady audible tone whenever an autotrim failure occurs. The autotrim system is monitored for the following failures: trim servo running without a command; trim servo not running when commanded to run; trim servo running in the wrong direction. The trim circuit breaker may be cycled off to silence the continuous tone but the trim fail light will remain on. The manual electric trim may be used but the autopilot should not be engaged.
6. **AUTOPILOT ANNUNCIATOR (AP)** - Illuminates continuously whenever the autopilot is engaged. Flashes approximately 12 times whenever the autopilot is disengaged (an aural alert will also sound for 2 seconds).
7. **AUTOPILOT ENGAGE (AP ENG) BUTTON** - When pushed, engages autopilot if all logic conditions are met.
8. **PREFLIGHT TEST (TEST) BUTTON** - When momentarily pushed, initiates preflight test sequence which automatically turns on all annunciator lights, tests the roll and pitch rate monitors, tests the autotrim fault monitor, checks the manual trim drive voltage and tests all autopilot valid and dump logic. If the preflight is successfully passed, the AP annunciator light will flash for approximately 6 seconds (an aural tone will also sound simultaneously with the annunciator flashes). The autopilot cannot be engaged until the autopilot preflight tests are successfully passed.
9. **BACK COURSE APPROACH (BC) MODE SELECTOR BUTTON** - When pushed, will select the Back Course Approach mode. This mode functions identically to the approach mode except that response to LOC signals is reversed. Glide slope coupling is inhibited in the Back Course Approach mode.
10. **APPROACH (APR) MODE SELECTOR BUTTON** - When pushed, will select the Approach mode. This mode provides all angle intercept (with HSI) or a fixed angle intercept of 45° (with DG), automatic beam capture and tracking of VOR, RNAV or LOC signals plus glide slope coupling in the case of an ILS. The tracking gain of the APR mode is greater than the gain in the NAV mode. The APR annunciator will flash until the automatic capture sequence is initiated.

Figure 7-3 (cont)

11. **NAVIGATION (NAV) MODE SELECTOR BUTTON** - When pushed, will select the Navigation mode. The mode provides all angle intercept (with HSI) or a fixed angle intercept of 45° (with DG), automatic beam capture and tracking of VOR, RNAV or LOC signals. The NAV annunciator will flash until the automatic capture sequence is initiated.
12. **HEADING (HDG) MODE SELECTOR BUTTON** - When pushed, will select the Heading mode, which commands the airplane to turn to and maintain the heading selected by the heading bug on the DG or HSI. A new heading may be selected at any time and will result in the airplane turning to the new heading with a maximum bank angle of about 20°. Selecting HDG mode will cancel NAV, APR or BC track modes.
13. **ALTITUDE HOLD (ALT) MODE SELECTOR BUTTON** - When pushed, will select the Altitude Hold mode, which commands the airplane to maintain the pressure altitude existing at the moment of selection. Engagement may be accomplished in climb, descent, or level flight. In the APR mode, altitude hold will automatically disengage when the glide slope is captured.



**KI 256 FLIGHT COMMAND INDICATOR**  
Figure 7-5

1. **KI 256 FLIGHT COMMAND INDICATOR (FCI)** - Displays airplane attitude as a conventional attitude gyro and displays commands for flight director operation. The gyro is air driven.
2. **ROLL ATTITUDE INDEX** - Displays airplane roll attitude with respect to the roll attitude scale.
3. **ROLL ATTITUDE SCALE** - Scale marked at 0,  $\pm 10$ ,  $\pm 20$ ,  $\pm 30$ ,  $\pm 60$  and  $\pm 90$  degrees.
4. **PITCH ATTITUDE SCALE** - Moves with respect to the symbolic airplane to present pitch attitude. Scale graduated at 0,  $\pm 5$ ,  $\pm 10$ ,  $\pm 15$ ,  $\pm 20$  and  $\pm 25$  degrees.
5. **COMMAND BAR** - Displays computed steering commands referenced to the symbolic airplane. The command bar is visible only when FD mode is selected. The command bar will be biased out of view whenever the system is invalid or a Flight Director mode is not engaged.
6. **FCI SYMBOLIC AIRPLANE** - Airplane pitch and roll attitude is displayed by the relationship between the fixed symbolic airplane and the movable background. During flight director operation, the symbolic airplane is flown to align it with the command bar to satisfy the flight director commands.
7. **DECISION HEIGHT (DH) ANNUNCIATOR LIGHT** - Optional light for use with the aircraft's optional radar altimeter.

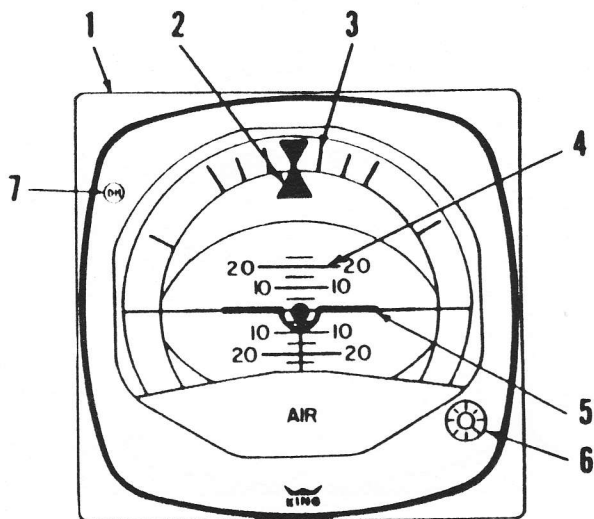

**KG 258 VERTICAL GYRO**

Figure 7-7

1. **KG 258 VERTICAL GYRO** - Displays airplane attitude as a conventional attitude gyro. The gyro is air driven.
2. **ROLL ATTITUDE INDEX** - Displays airplane roll attitude with respect to the roll attitude scale.
3. **ROLL ATTITUDE SCALE** - Scale marked at 0,  $\pm 10$ ,  $\pm 20$ ,  $\pm 30$ ,  $\pm 60$  and  $\pm 90$  degrees.
4. **PITCH ATTITUDE SCALE** - Moves with respect to the symbolic airplane to present pitch attitude. Scale graduated at 0,  $\pm 5$ ,  $\pm 10$ ,  $\pm 15$ ,  $\pm 20$  and  $\pm 25$  degrees.
5. **SYMBOLIC AIRPLANE** - Serves as a stationary symbol of the aircraft. Aircraft pitch and roll attitudes are displayed by the relationship between the fixed symbolic aircraft and the movable background.
6. **SYMBOLIC AIRCRAFT ALIGNMENT KNOB** - Provides manual positioning of the symbolic aircraft for level flight under various load conditions.
7. **DECISION HEIGHT (DH) ANNUNCIATOR LIGHT** - Optional light for use with the aircraft's optional radar altimeter.

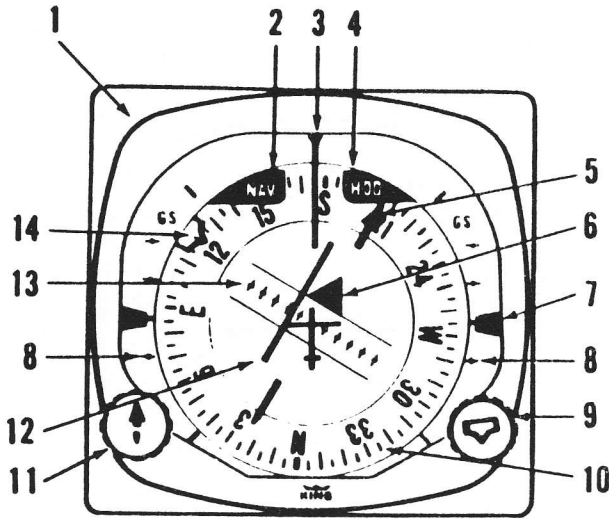



**KI 525A HORIZONTAL SITUATION INDICATOR**

Figure 7-9

1. **KI 525A HORIZONTAL SITUATION INDICATOR (HSI)** - Provides a pictorial presentation of aircraft deviation relative to VOR radials or localizer beams. It also displays glide slope deviations and gives heading reference with respect to magnetic north.
2. **NAV FLAG** - Flag is in view when the NAV receiver signal is inadequate. When a NAV flag is present in the navigation indicator (CDI or KI 525A) the autopilot operation is not affected. The pilot must monitor the navigation indicators for NAV flags to insure that the Autopilot and/or Flight Director are tracking valid navigation information.
3. **LUBBER LINE** - Indicates aircraft magnetic heading on compass card (10).
4. **HEADING WARNING FLAG (HDG)** - When flag is in view, the heading display is invalid. If a HDG flag appears and a lateral mode (HDG, NAV, APR or APR BC) is selected, the Autopilot will be disengaged. The Autopilot may be re-engaged in the basic wings level mode along with any vertical mode. The CWS switch would be used to maneuver the aircraft laterally.

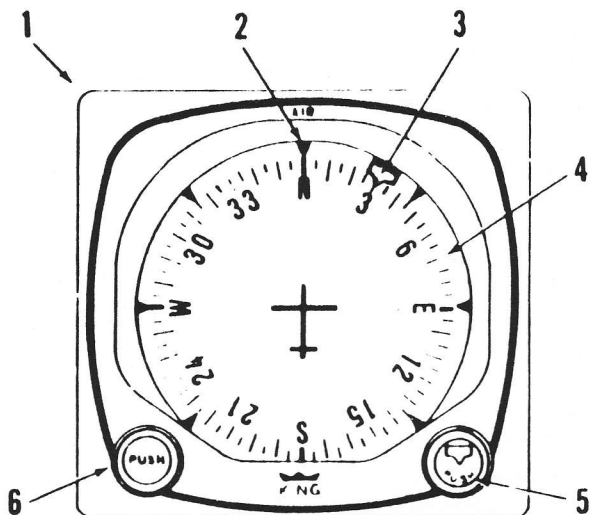

Figure 7-9 (cont)

5. COURSE BEARING POINTER - Indicates selected VOR course or localizer course on compass card (10). The selected VOR radial or localizer heading remains set on the compass card when the compass card (10) rotates.
6. TO/FROM INDICATOR FLAG - Indicates direction of VOR station relative to selected course.
7. DUAL GLIDE SLOPE POINTERS - Indicate on glide slope scale (8) aircraft displacement from glide slope beam center. Glide slope pointers in view indicate a usable glide slope signal is being received.
8. GLIDE SLOPE SCALES - Indicate displacement from glide slope beam center. A glide slope deviation bar displacement of 2 dots, represents full scale (0.7°) deviation above or below glide slope beam centerline.
9. HEADING SELECTOR KNOB (  ) - Positions heading bug (14) on compass card (10) by rotating the heading selector knob. The Bug rotates with the compass card.
10. COMPASS CARD - Rotates to display heading of airplane with reference to lubber line (3).
11. COURSE SELECTOR KNOB - Positions course bearing pointer (5) on the compass card (10) by rotating the course selector knob.
12. COURSE DEVIATION BAR (D-BAR) - The center portion of omni bearing pointer moves laterally to pictorially indicate the relationship of aircraft to the selected course. It indicates degrees of angular displacement from VOR radials and localizer beams, or displacement in nautical miles from RNAV courses.
13. COURSE DEVIATION SCALE - A course deviation bar displacement of 5 dots represents full scale (VOR =  $\pm 10^\circ$ , LOC =  $\pm 2 \frac{1}{2}^\circ$ , RNAV = 5NM, RNAV APR =  $1 \frac{1}{4}$ NM) deviation from beam centerline.
14. HEADING BUG - Moved by (  ) knob (9) to select desired heading.



**KG 107 NON-SLAVED DIRECTIONAL GYRO**

Figure 7-11

1. **KG 107 NON-SLAVED DIRECTIONAL GYRO (DG)** - Provides a stable visual indication of aircraft heading to the pilot. The gyro is air driven.
2. **LUBBER LINE** - Indicates aircraft magnetic heading on compass card (4).
3. **HEADING BUG** - Moved by (  ) knob (5) to select desired heading.
4. **COMPASS CARD** - Rotates to display heading of airplane with reference to lubber line (2) on DG.
5. **HEADING SELECTOR KNOB** (  ) - Positions heading bug (3) on compass card (4) by rotating the heading selector knob. The Bug rotates with the compass card.
6. **GYRO ADJUSTMENT KNOB (PUSH)** - When pushed in, allows the pilot to manually rotate the gyro compass card (4) to correspond with the magnetic heading indicated by the magnetic compass. The unslaved compass card must be manually reset periodically to compensate for precessional errors in the gyro.

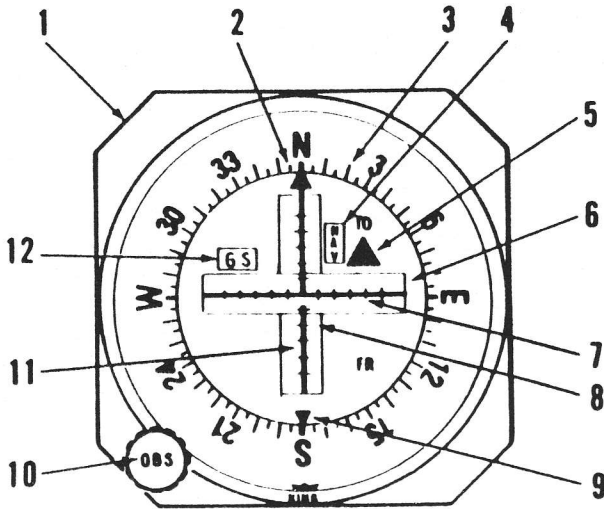

**KI 204/206 VOR/LOC/  
GLIDE SLOPE INDICATOR (TYPICAL)**

Figure 7-13

1. **VOR/LOC/GLIDE SLOPE INDICATOR** - Provides rectilinear display of VOR/LOC and glide slope deviation.
2. **COURSE INDEX** - Indicates selected VOR course.
3. **COURSE CARD** - Indicates selected VOR course under course index.
4. **NAV FLAG** - Flag is in view when the NAV receiver signal is inadequate. When a NAV flag is present in the navigation indicator (CDI or KI 525A), the autopilot operation is not affected. The pilot must monitor the navigation indicators for NAV flags to insure that the Autopilot and/or Flight Director are tracking valid navigation information.
5. **TO/FROM INDICATOR FLAG** - Indicates direction of VOR station relative to selected course.
6. **GLIDE SLOPE DEVIATION NEEDLE** - Indicates deviation from U.S glide slope.
7. **COURSE DEVIATION SCALE** - A course deviation bar displacement of 5 dots represents full scale (VOR =  $\pm 10^\circ$ , LOC =  $\pm 2 \frac{1}{2}^\circ$ , RNAV = 5NM, RNAV APR =  $\pm 1 \frac{1}{4}$ NM) deviation from beam centerline.



Figure 7-13 (cont)

8. **GLIDE SLOPE SCALE** - Indicates displacement from glide slope beam center. A glide slope deviation needle displacement of 5 dots, represents full scale ( $0.7^\circ$ ) deviation above or below glide slope beam centerline.
9. **RECIPROCAL COURSE INDEX** - Indicates reciprocal of selected VOR course.
10. **OMNI BEARING SELECTOR (OBS) KNOB** - Rotates course card to selected course.
11. **COURSE DEVIATION NEEDLE** - Indicates course deviation from selected omni course or localizer centerline.
12. **GLIDE SLOPE (GS) FLAG** - Flag is in view when the GS receiver signal is inadequate.

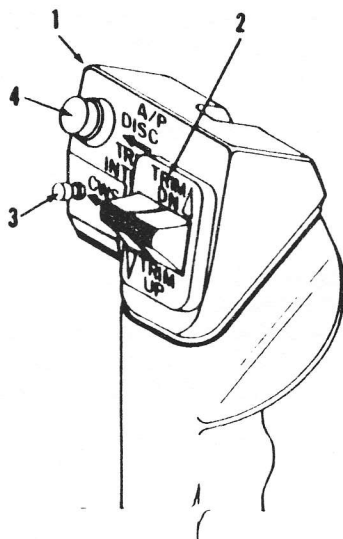

**AUTOPILOT CONTROL WHEEL SWITCH CAP**

Figure 7-15

Figure 7-15 (cont)

1. **AUTOPILOT CONTROL WHEEL SWITCH CAP** - Molded plastic unit mounted on the left horn of the pilot's control wheel which provides mounting for three switch units associated with the autopilot and manual electric trim systems.
2. **MANUAL ELECTRIC TRIM CONTROL SWITCHES** - A split switch unit in which the left half provides power to engage the trim servo clutch and the right half to control the direction of motion of the trim servo motor. Both halves of the split trim switch must be actuated in order for the manual trim to operate in the desired direction. When the autopilot is engaged, operation of the manual electric trim will automatically disconnect the autopilot.
3. **CONTROL WHEEL STEERING (CWS) BUTTON** - When depressed, allows pilot to manually control the aircraft (disengages the servos) without cancellation of any of the selected modes. Will engage the Flight Director mode if not previously engaged. Automatically synchronizes the Flight Director/Autopilot to the pitch attitude present when the CWS switch is released, or to the present pressure altitude when operating in the ALT hold mode. Will cancel GS couple. The aircraft must pass through the glide slope to allow GS recouple.
4. **AUTOPILOT DISCONNECT/TRIM INTERRUPT (AP DISC/TRIM INTER) Switch** - When depressed and released will disengage the autopilot and cancel all operating Flight Director modes. When depressed and held will interrupt all electric trim power (stop trim motion), disengage the autopilot, and cancel all operating Flight Director modes.

The airplane MASTER SWITCH function is unchanged and can be used in an emergency to shut off electrical power to all flight control systems while the problem is isolated.

The RADIO POWER switch supplies power to the avionics buss bar of the radio circuit breakers and the autopilot circuit breaker.

The following circuit breakers are used to protect the following elements of the King 150 Series Autopilot:

**AUTOPILOT** - Supplies power to the KC 192 or the KC 191 Computer, the autopilot pitch and roll servos, and the Pitch Trim Circuit Breaker.

**PITCH TRIM** - Supplies power to the autotrim and manual electric pitch trim systems.

**COMP-SYSTEM** - Supplies power to the optional KCS 55A Compass System.

**SUPPLEMENT 9**

**KNS 80 NAVIGATION SYSTEM**

**SECTION 1 - GENERAL**

This supplement supplies information necessary for the operation of the airplane when the optional KNS 80 Navigation System is installed. The information contained within this supplement is to be used in conjunction with the complete handbook.

This supplement has been "FAA Approved" as a permanent part of this handbook and must remain in this handbook at all times when the optional KNS 80 Navigation System is installed.

**SECTION 2 - LIMITATIONS**

No changes to the basic limitations provided by Section 2 of this Pilot's Operating Handbook are necessary for this supplement.

**SECTION 3 - EMERGENCY PROCEDURES**

No changes to basic Emergency Procedures provided by Section 3 of this Pilot's Operating Handbook are necessary for this supplement.

**SECTION 4 - NORMAL PROCEDURES**

**(a) KNS 80 OPERATION**

The KNS 80 can be operated in any one of 3 basic modes: (a) VOR, (b) RNAV, or (c) ILS. To change from one mode to another, the appropriate pushbutton switch is pressed, except that the ILS mode is entered automatically whenever an ILS frequency is channeled in the USE waypoint. The display will annunciate the mode by lighting a message above the pushbutton. In addition to the standard VOR and RNAV enroute (RNV ENR) modes, the KNS 80 has a constant course width or parallel VOR mode (VOR PAR) and an RNAV approach mode (RNV APR). To place the unit in either of these secondary modes the VOR pushbutton or the RNAV pushbutton, as the case may be, is pushed a second time. Repetitive pushing of the VOR button will cause the system to alternate between the VOR and VOR PAR modes, while repetitive pushing of the RNAV button causes the system to alternate between RNV ENR and RNV APR modes.

**(b) CONTROLS**

**(1) VOR BUTTON**

Momentary pushbutton.

When pushed while system is in either RNV mode causes system to go to VOR mode. Otherwise the button causes system to toggle between VOR and VOR PAR modes.

**(2) RNAV BUTTON**

Momentary pushbutton.

When pushed while system is in either VOR mode causes system to go to RNV ENR mode. Otherwise the button causes system to toggle between RNV ENR and RNV APR modes.

**(3) HOLD BUTTON**

Two position pushbutton.

When in depressed position, inhibits DME from channeling to a new station when the VOR frequency is changed. Pushing the button again releases the button and channels the DME to the station paired with the VOR station.

**(4) USE BUTTON**

Momentary pushbutton.

Causes active waypoint to take on same value as displayed waypoint and data display to go to FRQ mode.

- (5) **DSP BUTTON**  
Momentary pushbutton.  
Causes displayed waypoint to increment by 1 and data display to go to frequency mode.
- (6) **DATA BUTTON**  
Momentary pushbutton.  
Causes waypoint data display to change from FRQ to RAD to DST and back to FRQ.
- (7) **OFF/PULL ID CONTROL**  
a. Rotate counterclockwise to switch off power to the KNS 80.  
b. Rotate clockwise to increase audio level.  
c. Pull switch out to hear VOR Ident.
- (8) **DATA INPUT CONTROL**  
Dual concentric knobs. Center knob has "in" and "out" positions.  
a. **Frequency Data**  
Outer knob varies 1 MHz digit.  
A carryover occurs from the units to the tens position.  
Rollover occurs from 117 to 108, or vice versa.  
Center knob varies frequency in .05 MHz steps regardless of whether the switch is in its in or out position.  
b. **Radial Data**  
Outer knob varies 10 degree digit.  
A carryover occurs from tens to hundreds position.  
A rollover to zero occurs at 360 degrees.  
Center knob "in" position varies 1 degree digit.  
Center knob "out" position varies 0.1 degree digit.  
c. **Distance Data**  
Outer knob varies 10 NM digit.  
A carryover occurs from the tens to hundreds place.  
A rollover to zero occurs at 200 NM.  
Center knob "in" position varies 1 NM digit.  
Center knob "out" position varies 0.1 NM digit.
- (9) **COURSE SELECT KNOB**  
Located in CDI unit.  
Selects desired course through the VOR ground station or waypoint.

**SECTION 5 - PERFORMANCE**

No changes to the basic performance provided by Section 5 of this Pilot's Operating Handbook are necessary for this supplement.

PILOT'S OPERATING HANDBOOK  
AND  
FAA APPROVED AIRPLANE FLIGHT MANUAL  
  
SUPPLEMENT No. 10  
FOR  
AUXILIARY VACUUM SYSTEM

This supplement must be attached to the Pilot's Operating Handbook and FAA Approved Airplane Flight Manual when the Piper Auxiliary Vacuum System is installed in accordance with Piper Drawing No. 87774-2. The information contained herein supplements or supersedes the Pilot's Operating Handbook and FAA Approved Airplane Flight Manual only in those areas listed. For limitations, procedures, and performance information not contained in this supplement, consult the Pilot's Operating Handbook and FAA Approved Airplane Flight Manual.

FAA APPROVED \_\_\_\_\_



D.H. TROMPLER  
D.O.A. NO. SO-1  
PIPER AIRCRAFT CORPORATION  
VERO BEACH, FLORIDA

DATE OF APPROVAL \_\_\_\_\_

12/3/86



**SECTION 1 - GENERAL**

This supplement supplies information necessary for the operation of the airplane when the optional Piper Auxiliary Vacuum System is installed. The information contained within this supplement is to be used in conjunction with the complete handbook.

**SECTION 2 - LIMITATIONS**

1. The auxiliary vacuum system is limited to standby function only. Take off with the engine driven dry air pump inoperative is not approved.
2. Discontinue flight in instrument meteorological conditions (IMC) if vacuum pressure falls below 4.8 In. Hg.
3. The auxiliary pump/motor assembly and elapsed time indicator must be removed from service after 500 hours accumulated operating time or 10 years, whichever occurs first.

**SECTION 3 - EMERGENCY PROCEDURES**

**LOSS OF VACUUM SUCTION** - Low vacuum (VAC) annunciator and VAC OFF warning lamp lit.

1. Vacuum gauge ..... fCheck to verify inoperative pump. If vacuum gauge reads below 4.5 inches of mercury:
2. Auxiliary vacuum switch..... Press AUX ON.
3. Verify vacuum pressure of 4.8 to 5.2 inches of mercury.
4. Verify VAC annunciator and VAC OFF lights go out.

**CAUTION**

Compass error may exceed 10° when auxiliary vacuum system is in operation.

5. Electrical load ..... Monitor
  - a. Verify alternator capacity is not being exceeded.
  - b. If required, turn off nonessential electrical equipment.

**SECTION 4 - NORMAL PROCEDURES**

- A. Preflight Check.
1. Set battery switch on and verify that VAC OFF lamp lights.

**NOTE**

Due to electrical power requirement of the auxiliary vacuum pump it is suggested that the engine be operating while making the following checks.

2. Turn on auxiliary vacuum pump on and verify AUX ON light is illuminated and electrical load is approximately 15 amps on ammeter.
  3. Turn off auxiliary vacuum pump and verify AUX ON light goes out.
- B. Inflight Check - Prior to entering instrument flight conditions.
1. Turn off non-essential electrical equipment.
  2. Turn on auxiliary vacuum pump and verify AUX ON light illuminated and electrical load is approximately 15 amps on ammeter.
  3. Turn off auxiliary vacuum pump and verify AUX ON light goes out.

**NOTE**

For maximum service life, avoid continuous non-emergency operation of the auxiliary vacuum pump.

**SECTION 5 - PERFORMANCE**

No change.

**SECTION 6 - WEIGHT & BALANCE**

Factory installed optional equipment is included in the licensed weight and balance data in section 6 of the Pilot's Operating Handbook.

## **SECTION 7 - DESCRIPTION AND OPERATION**

The auxiliary dry air pump system provides an independent back-up source of pneumatic power to operate the gyro flight instruments in the event the engine driven air pump fails.

The auxiliary pump is mounted on the forward side of the firewall and connects to the primary system at a manifold downstream of the vacuum regulator. Isolation of the primary and auxiliary systems from each other is accomplished by check valves on each side of the manifold. The primary system vacuum switch is located on the regulator and senses vacuum supplied to the gyros.

A control switch (labeled AUX VAC) for the auxiliary pump system is located on the right side of the instrument panel near the vacuum suction gage.

The switch button incorporates two annunciator light sections labeled VAC OFF and AUX ON. The VAC OFF section is controlled by a vacuum switch in the primary pneumatic system and illuminates an amber light when the engine driven pump is inoperative or when the system vacuum falls below the switch activation level. The AUX ON section is controlled by a vacuum switch on the manifold and illuminates a blue light when the auxiliary pump is operating and creating a vacuum in the system. When the auxiliary pump is activated at high altitude, or if the system has developed air leaks, the AUX ON light may fail to illuminate. This indicates that the system vacuum is still below the AUX ON switch activation level even though the auxiliary pump is operating. The annunciator lights do not incorporate a press-to-test feature, if the lights do not illuminate as expected, check for burned out lamps, replace with MS25237-330 bulbs and retest the system.

System electrical protection is provided by a 20 amp circuit breaker in the pump motor circuit and a 5 amp circuit breaker in the annunciator light circuit. The breakers are mounted on the circuit breaker panel.

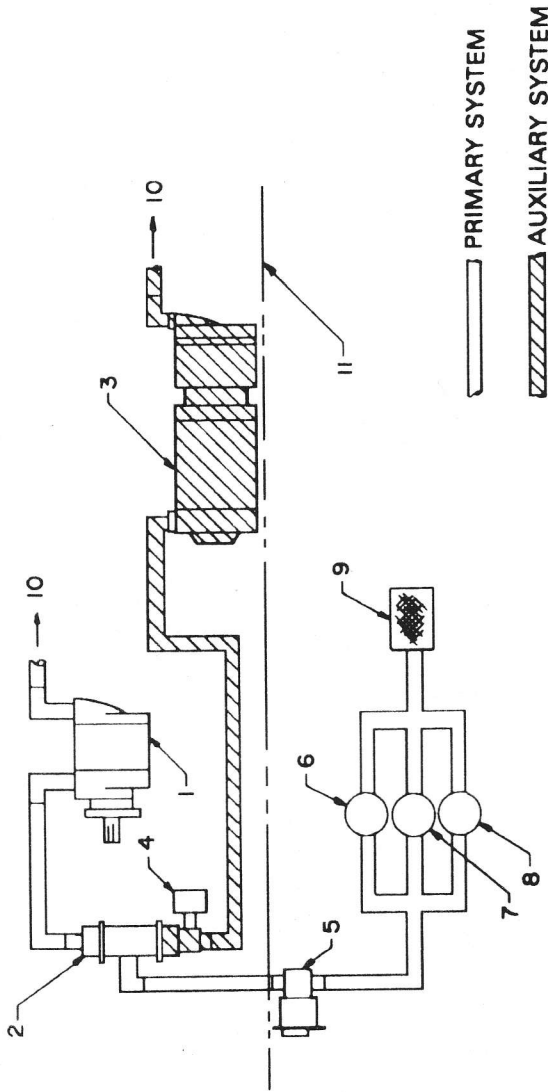

- 1. ENGINE DRIVEN DRY AIR PUMP
- 2. MANIFOLD & CHECK VALVE ASSY.
- 3. AUX. ELECTRICALLY DRIVEN DRY AIR PUMP
- 4. PRESSURE SENSING SWITCH
- 5. SYSTEM REGULATOR & PRESS. SENSING SWITCH
- 6. VACUUM (SUCTION) GAUGE
- 7. ATTITUDE GYRO
- 8. DIRECTIONAL GYRO
- 9. FILTER
- 10. OVERBOARD VENT
- 11. FIREWALL

**THIS PAGE INTENTIONALLY LEFT BLANK**

**PILOT'S OPERATING HANDBOOK  
AND  
FAA APPROVED AIRPLANE FLIGHT MANUAL  
SUPPLEMENT NO. 11  
FOR  
BENDIX/KING KLN 90 GPS  
NAVIGATION SYSTEM WITH  
KAP 150 AUTOPILOT SYSTEM**

This supplement must be attached to the Pilot's Operating Handbook and FAA Approved Airplane Flight Manual when the optional Bendix/King KLN 90 GPS Navigation System is installed per Equipment List. The information contained herein supplements or supersedes the information in the basic Pilot's Operating Handbook and FAA Approved Airplane Flight Manual only in those areas listed herein. For limitations, procedures and performance information not contained in this supplement, consult the basic Pilot's Operating Handbook and FAA Approved Airplane Flight Manual.

FAA APPROVED

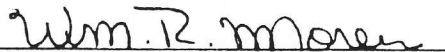

W. R. MOREU  
D.O.A. NO. SO.-1  
PIPER AIRCRAFT CORPORATION  
VERO BEACH, FLORIDA

DATE OF APPROVAL \_\_\_\_\_ JANUARY 07, 1993 \_\_\_\_\_

**SECTION 1 - GENERAL**

This supplement supplies information necessary for the operation of the airplane when the optional Bendix/King KLN 90 GPS Navigation System is installed. The Navigation System must be operated within the limitations herein specified. The information contained within this supplement is to be used in conjunction with the complete handbook.

This supplement has been FAA Approved as a permanent part of this handbook and must remain in this handbook at all times when the optional Bendix/King KLN 90 GPS Navigation System is installed.

**SECTION 2 - LIMITATIONS**

- (a) GPS limited to VFR use only.
- (b) The following placard is located on the pilots instrument panel adjacent to the HSI.

GPS LIMITED TO VFR USE ONLY

*CAUTION:*

The presently deployed GPS satellite constellation does not meet the coverage, availability, and integrity requirements for civil aircraft navigation equipment. Users are cautioned that satellite availability and accuracy are subject to change.

**SECTION 3 - EMERGENCY PROCEDURES**

No changes to the Basic Emergency Procedures provided by section 3 of this Pilot's Operating Handbook are necessary for this supplement.

## **SECTION 4 - NORMAL PROCEDURES**

### **(a) OPERATION**

Normal operating procedures are outlined in the Bendix/King KLN 90 GPS Navigation System, Pilots Guide (p/n 006-08484-000 dated August, 1992 or latest revision).

### **(b) EXTERNAL ANNUNCIATORS: (OPTIONAL)**

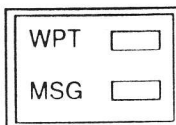

#### **1. Waypoint (WPT)**

Approximately 36 seconds prior to reaching a direct to waypoint or 20 seconds prior to the beginning of turn anticipation (turn anticipation function enabled) the waypoint alert annunciator will begin flashing. This is called "waypoint alerting".

#### **2. Message (MSG)**

MSG will flash to alert the pilot of a situation that requires attention. Press the MSG button on the KLN 90 GPS to view the message. (Appendix B of the Pilots Guide contains a list of all of the message page messages and their meanings).

## **SECTION 5 - PERFORMANCE**

Installation of the Bendix/King KLN 90 GPS does not affect the basic performance information in Section 5 of this Pilot's Operating Handbook.

## **SECTION 6 - WEIGHT AND BALANCE**

Factory installed optional equipment is included in the licensed weight and balance data in Section 6 of the basic Pilot's Operating Handbook.



**THIS PAGE INTENTIONALLY LEFT BLANK**